

# Materialcharakterisierung von faserverstärkten Kunststoffen in 4a impetus – Mikromechanische Ansätze als einfaches Hilfsmittel

A. Fertschej, P. Reithofer, B. Jilka,  
4a engineering GmbH

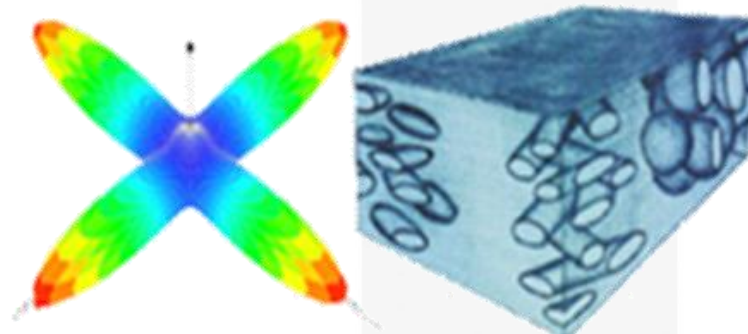

4a engineering GmbH  
Industriepark 1  
A-8772 Traboch  
fertschej@4a.co.at  
++43 (0) 664 80106 619



**Berechnung und Simulation:  
Anwendungen – Entwicklungen – Trends**  
25. – 27. April 2016, Bamberg

4a technology-group: founded in 2002

Location: Traboch, Austria

Number of employees > 80

Field of operation: global

Certificates: ISO 9001

more than 2000 projects

more than 400 customers

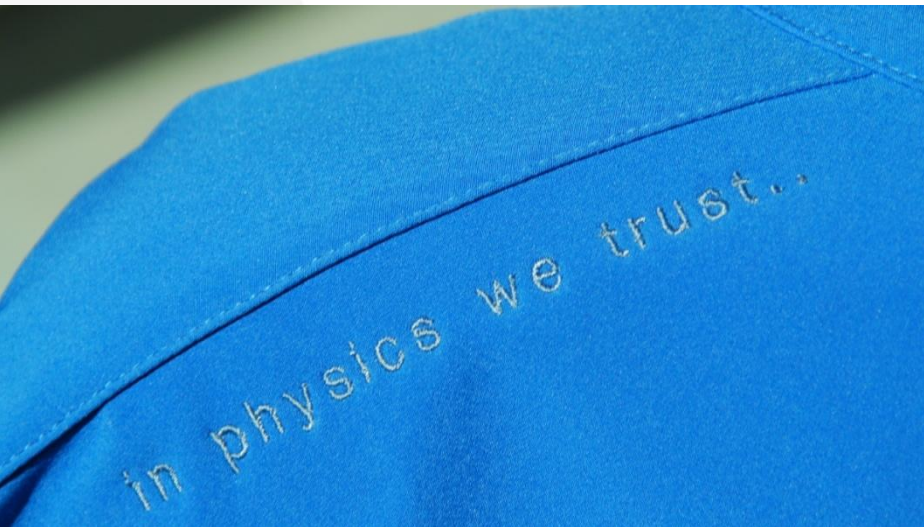



## Group of Companies

- 4a Group
- Philosophy
- People
- Products
- Press
- Contact
- Directions

>>> [JOBS](#)

[Company details](#)  
[Terms & Conditions](#)

DE|EN



IN PHYSICS WE TRUST

## Business units

Engineering and simulation for plastic products and components	Multi-layer composites and sandwich materials for cost-efficient	Testing facilities generating material data suitable for the dynamic simulation of plastics	Dummies and testing facilities for active vehicle safety





- polymer and materials science
- numerical simulation methods
- fiber reinforced plastics and composites
- method and software development
- material characterization
- product development



LH<sub>2</sub> – tank mounting:

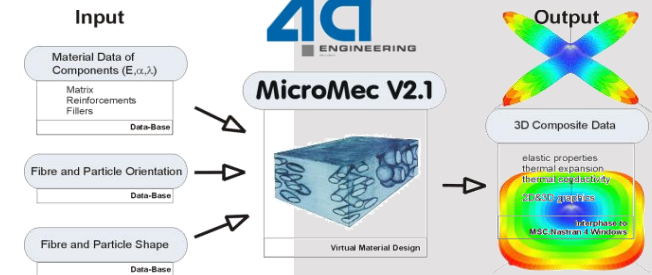
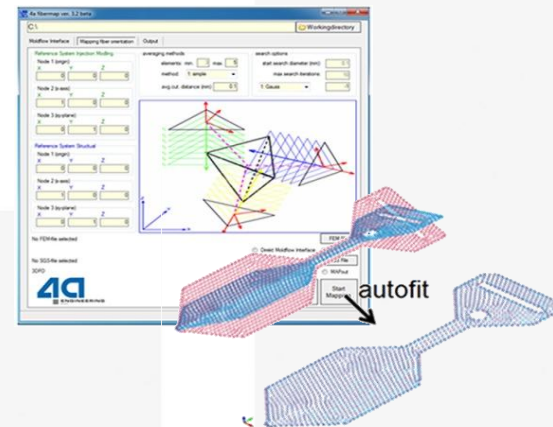
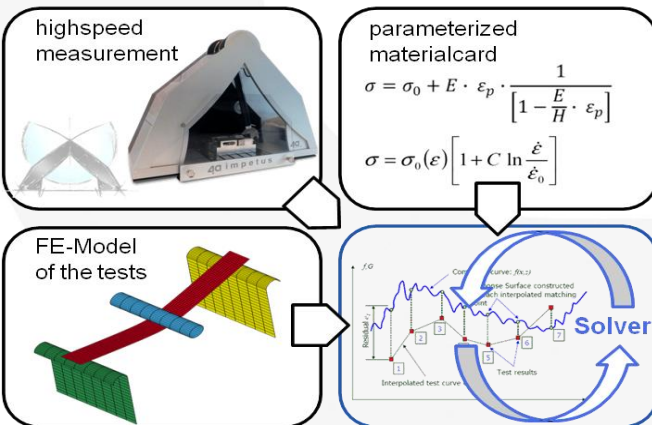
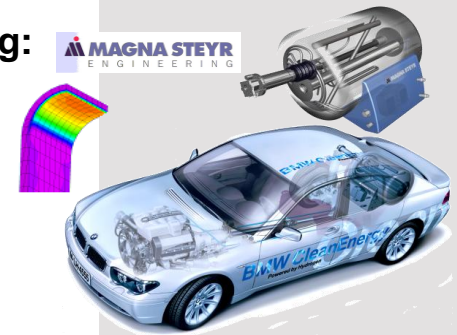

## 4a impetus

Pendulum testing device  
Numerical simulation  
Automatic material card (LS-Dyna...)

## 4a fibermap

Consideration of the fiber orientation in the structural simulation of short or long fiber reinforced thermoplastics

## 4a micromec

Micromechanical program  
Calculation of the thermo-mechanical properties of composites

- Introduction
- Exemplary material behavior  
fiber orientation and content – strain rate - temperature
- \*MAT\_24 – typical approach
- Available material models in LS-DYNA
- Micro mechanic based model
- Simulation process chain
- Case studies
- Conclusion

# Introduction

## Characteristic structure of reinforced plastics

**Fiber size and geometry** → significant influence on part performance

**Increasing fiber content** → orthotropic properties increase & effect of strain rate diminishes (less content of matrix material)

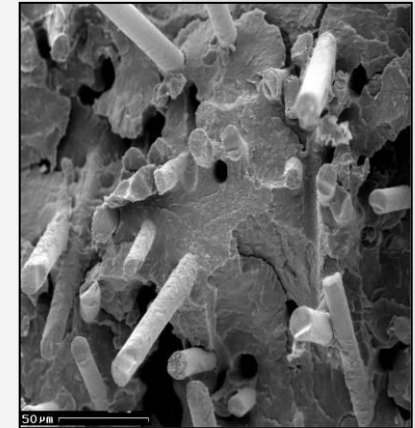
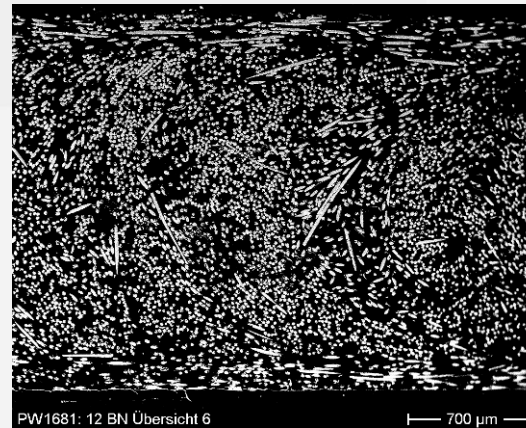

**4a experimental tool**

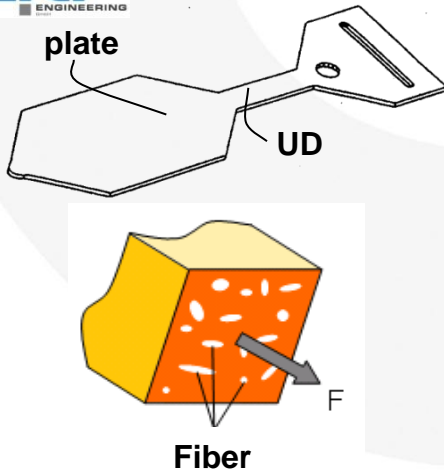

**dependence on fiber orientation**

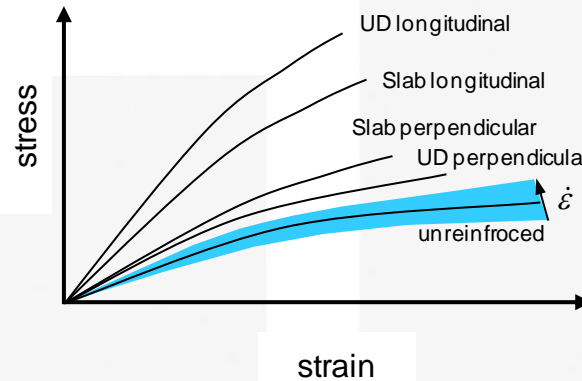

**dependence on fiber content**

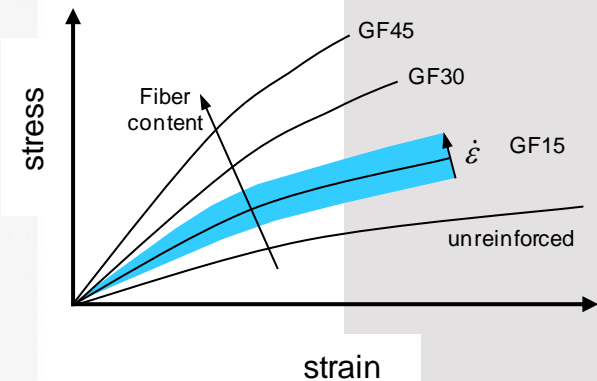

- efficient high-dynamic testing
- crash-behavior of plastics
- material data for simulation



bending test on 4a impetus

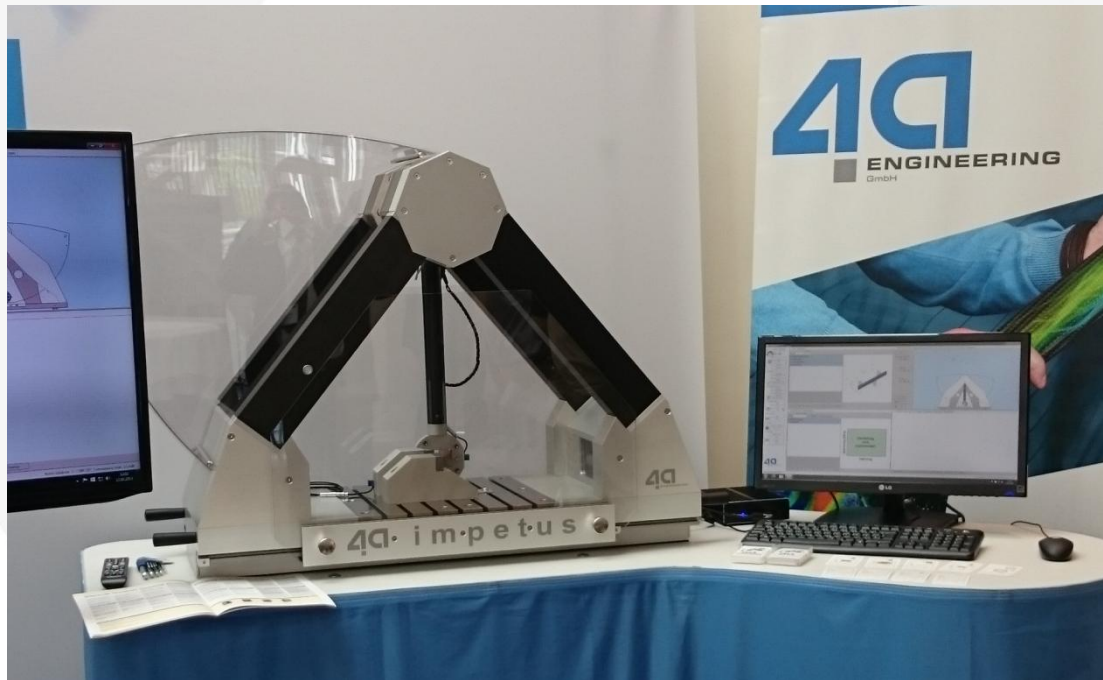

**4a impetus - intelligent testing systems  
powered by 4a engineering GmbH**

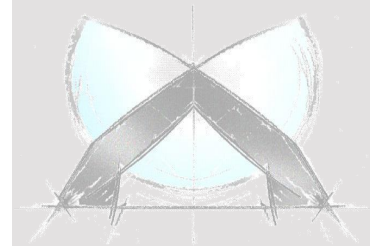

# Fiber reinforced thermoplastics

3-point-bending, support distance 50 mm

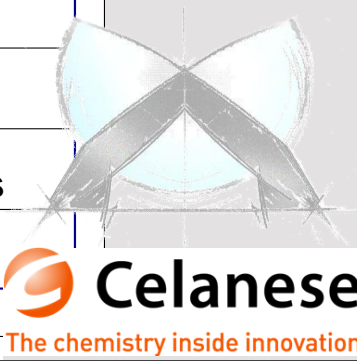
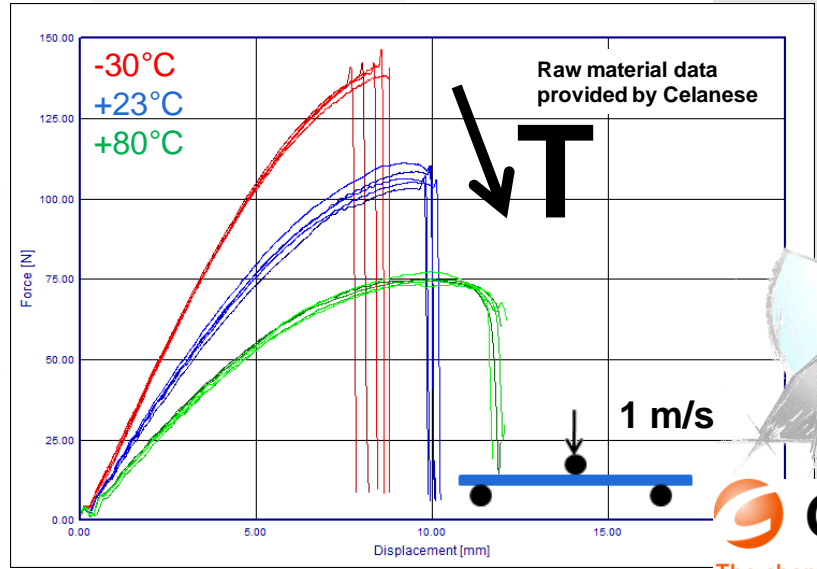
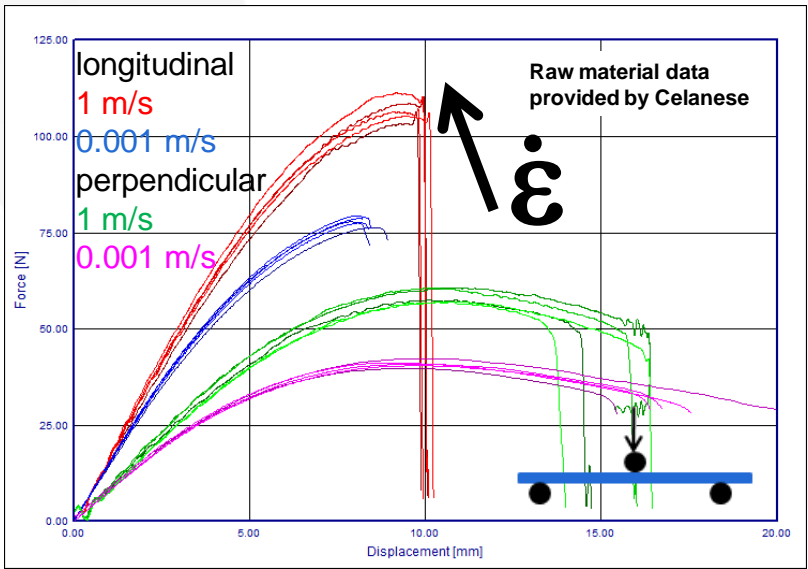
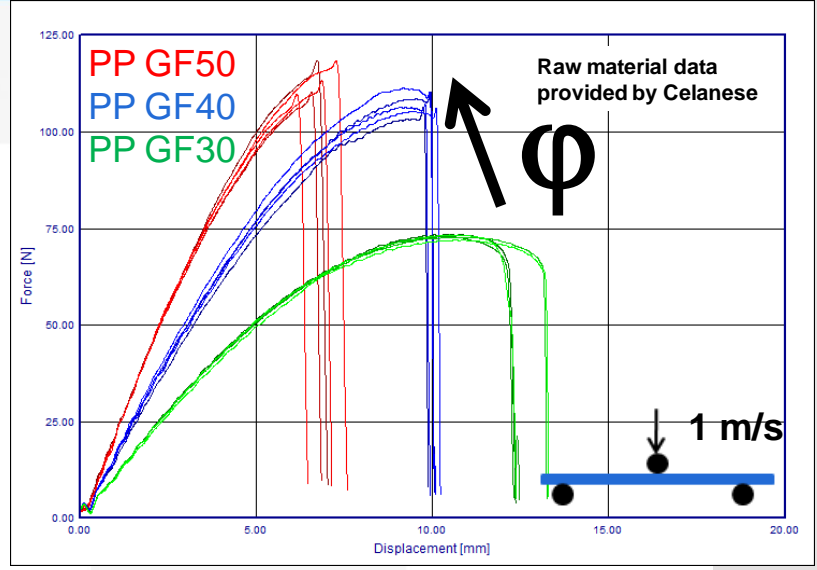
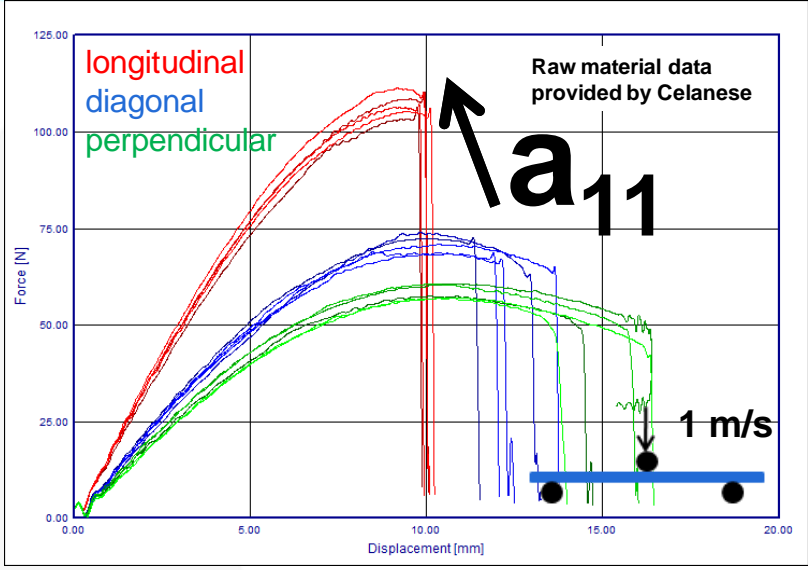



**4a Impetus v3.00 beta**

licensed for Peter Reithofer 4aengineering

Versuchsdaten: Neu, Kopieren, Prüfplan

Versuchsdurchführung: Set Winkel, Start, Report, Messkurven

Versuchsauswertung: Auswerten, Load Plots, Unload Plots, Mittelwertplots

Parametermodell: Neu, Kopieren, Hinzufügen

Optimierung: View, Start

Material: akt. Modell plotten, Karte erstellen

4a Impetus: Datenverzeichnis, Hilfe, Beenden

Versuch/Test: Database Tests

Datum\_Nr: 110125\_001

**Allgemeine Informationen**

**Prüfsetup**

**Probekörper**

**Auswertung**

Filter	0	kein Filter
Geschwindigkeitsermittlung	3 - Weg (statisch Anfangsanstieg)	
Nullpunktbestimmung	0 - manuelle (Zeitpunkt)	
Brucherkennung	0 - manuell (Zeitpunkt)	
Spannungsauswertung		
Steifigkeitsauswertung		
Ergebnisse		

3D Model Dimensions: L, LW, D, t

Messung | Report | Messkurven | Viewer | a(t) | v(t) | s(t) | F(t) | F(s) | E(t) | sig(eps) | epspkt(eps)

Channels [ ]

Externe Daten

211.20

**Parametermodell\* Modelle**

Datum\_Nr\_Name: 110501\_001

Material | Designvariable

**Modelleinstellungen**

**Werkstoff**

Materialklasse	
Materialtyp	Thermoplast unv.

**Materialverhalten**

Materialquelle	benutzerdefiniert
Materialkarte	339

**Idealisierung**

Einheitensystem	SI(kg-m-sec-Pa)
Solver	LS DYNA
Inputdeck	customized
Modellsymmetrie	Viertelmodell
Elementtyp	Solid Hexaeder
Elementgröße	2
Kontaktstärke	0
Elementschichten	0
Benutzerdefinierter Parameter	0

Force vs. Displacement Graph:

Kraft [N]

Weg [mm]

26.09, 17.39, 6.70, -0.00

0.00, 5.15, 10.29, 15.44, 20.59

Active Datenbank: L:\UA\EN\Projekte\11052101\_hostacom\vnair\_v3.mdb

**Complete system  
from the test to the validated  
material card**

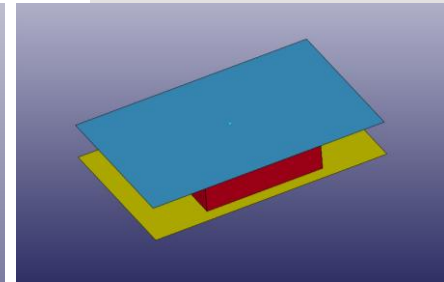
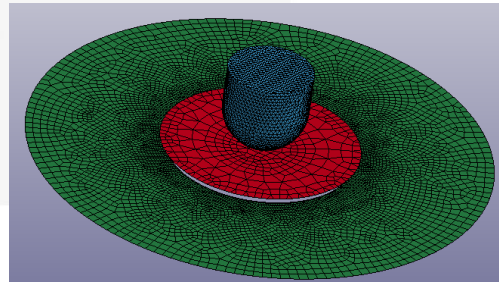
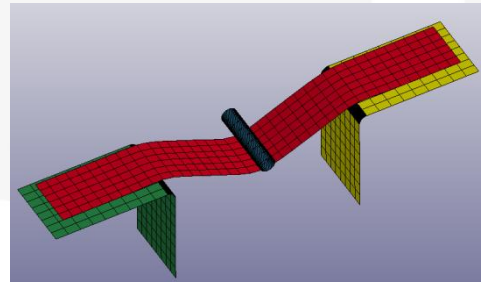
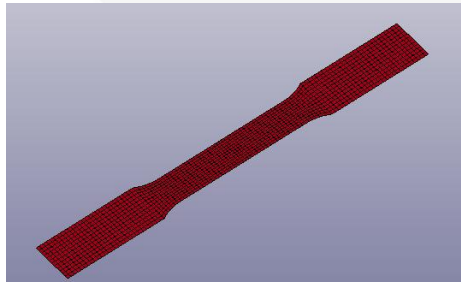

[2005Fritz]

# \*MAT\_24 – typical approach

Separate for each direction

FE-Model of the test

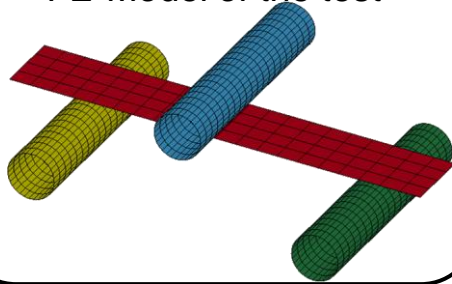

Parameterized materialcard

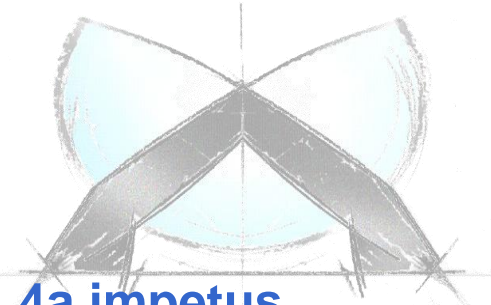
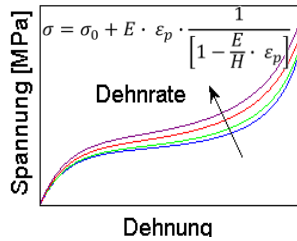

4a impetus

© by 4a engineering GmbH - intelligent testing systems

Hyperview, Animator, LS PREPOST, ...

DATABASE  
measurement, models

$$\epsilon = \frac{1}{P} \sum_{i=1}^P W_i \left( \frac{f_i(x) - G_f}{\epsilon_p} \right)^2 = \frac{1}{P} \sum_{i=1}^P W_i \left( \frac{\sigma_i(x)}{\epsilon_p} \right)^2$$

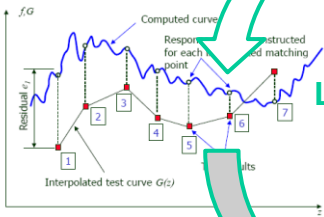

LS DYNA, ABAQUS, PAM CRASH, ...

Reverse Engineering

# \*MAT\_24 – typical approach

Separate for each direction

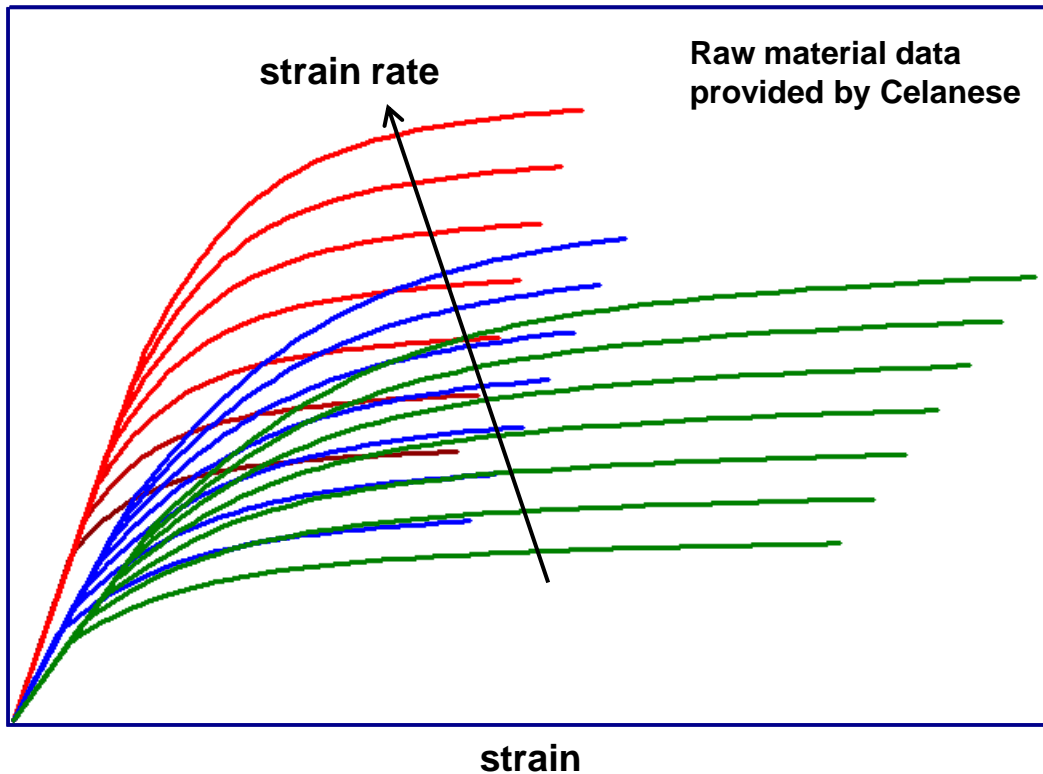

PP GF40

longitudinal  
diagonal  
perpendicular

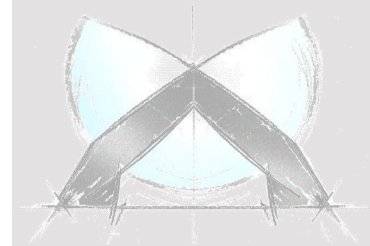

**4a IMPETUS**

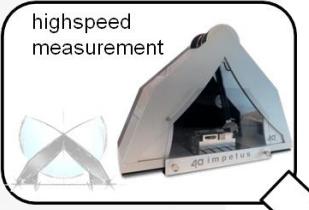

parameterized materialcard

$$\sigma = \sigma_0 + E \cdot \varepsilon_p \cdot \frac{1}{\left[1 - \frac{E}{H} \cdot \varepsilon_p\right]}$$

$$\sigma = \sigma_0(\varepsilon) \left[1 + C \ln \frac{\dot{\varepsilon}}{\dot{\varepsilon}_0}\right]$$

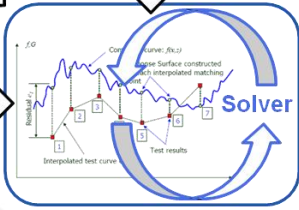
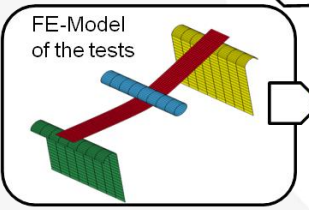

**validated material cards**

**4a FIBERMAP**

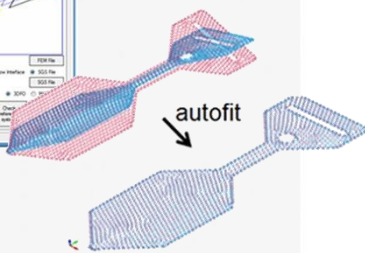
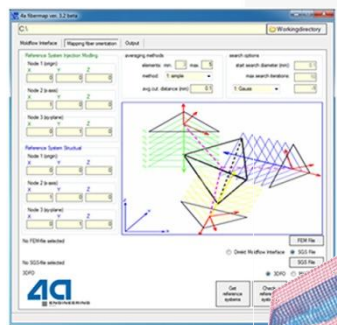

**individual mapping process information**

**4a MICROMECH**

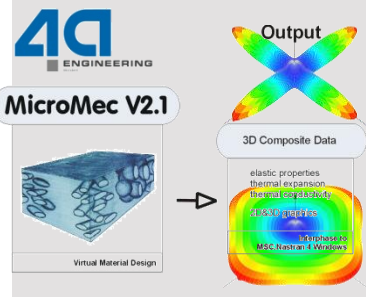
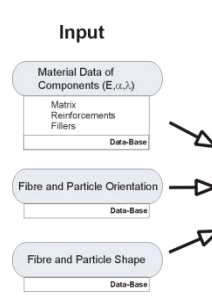

**3D thermo elastic anisotropic material cards**



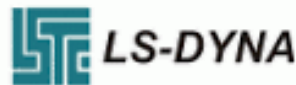
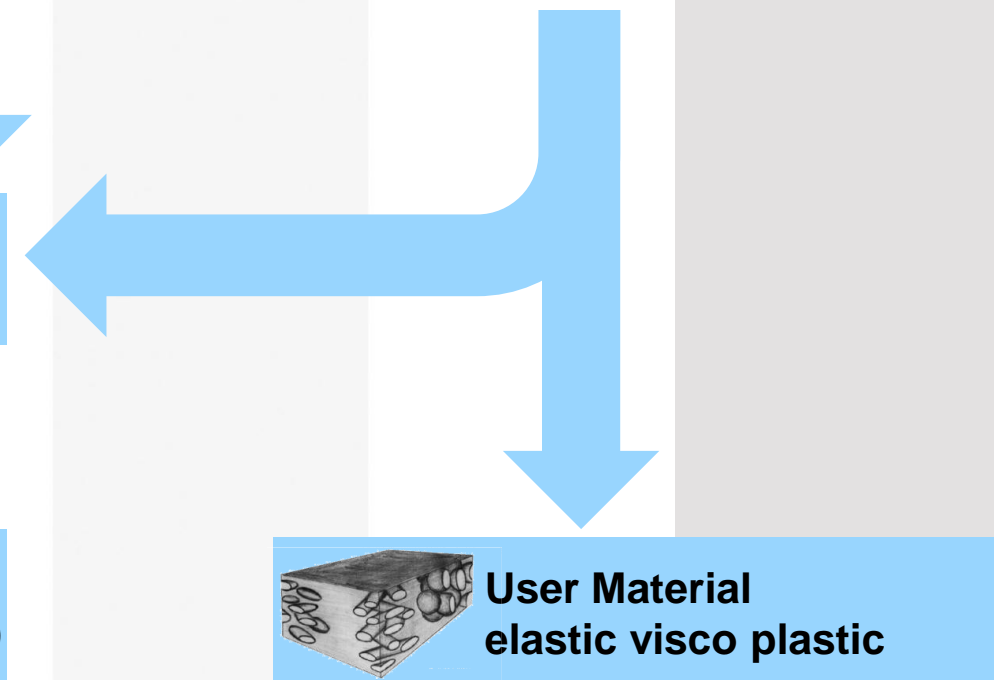
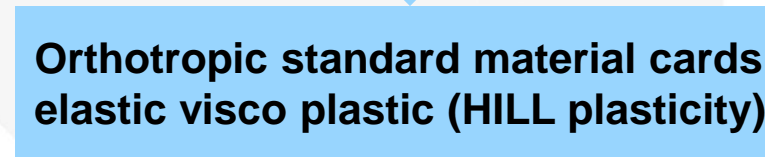
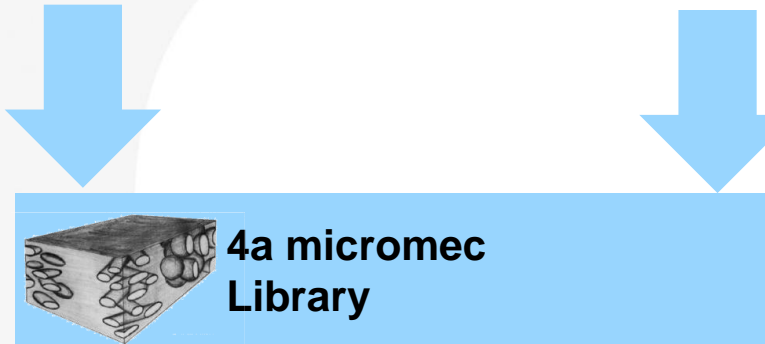

# Micro mechanic based material models

Stand-alone product - calculating the elastic values

## Input

Material Data of Components ( $E, \alpha, \lambda$ )

Matrix  
Reinforcements  
Fillers

Data-Base



Fibre and Particle Orientation

Data-Base



Fibre and Particle Shape

Data-Base



since 1999

### 4a micromec

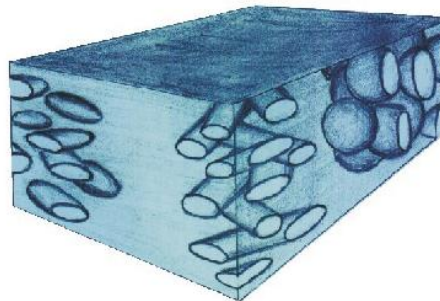

Virtual Material Design



## Output

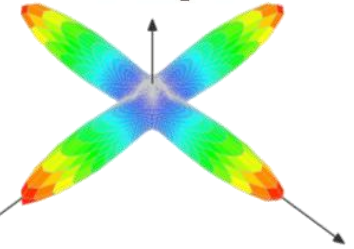

3D Composite Data

elastic properties  
thermal expansion  
thermal conductivity  
2D&3D graphics

Interphase to  
MSC.Nastran 4 Windows

- SFRT, LFRT, CFRP, GFRP, .....
- 3D thermo-elastic properties

# Micro mechanic based material models

## Stand-alone product - calculating the elastic values

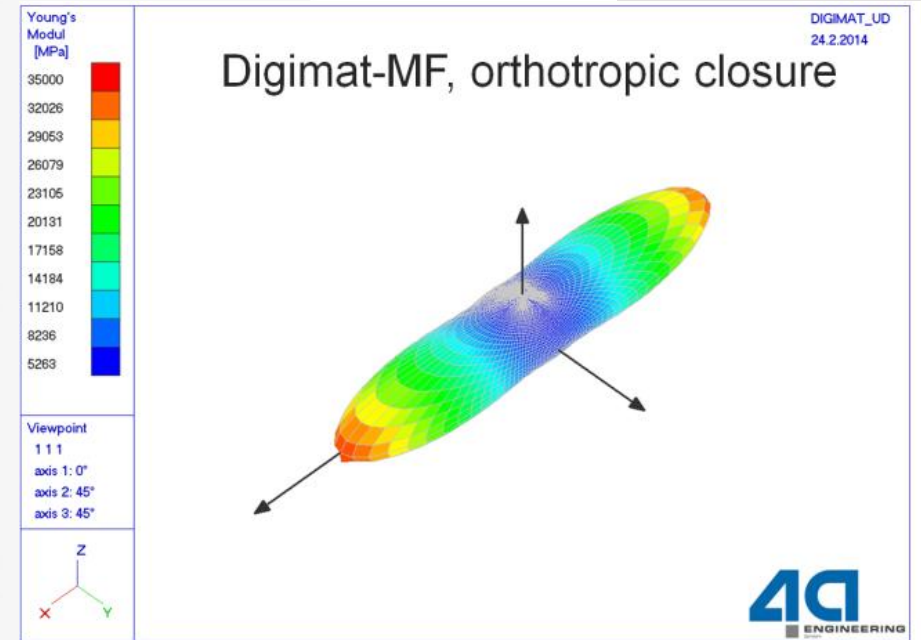
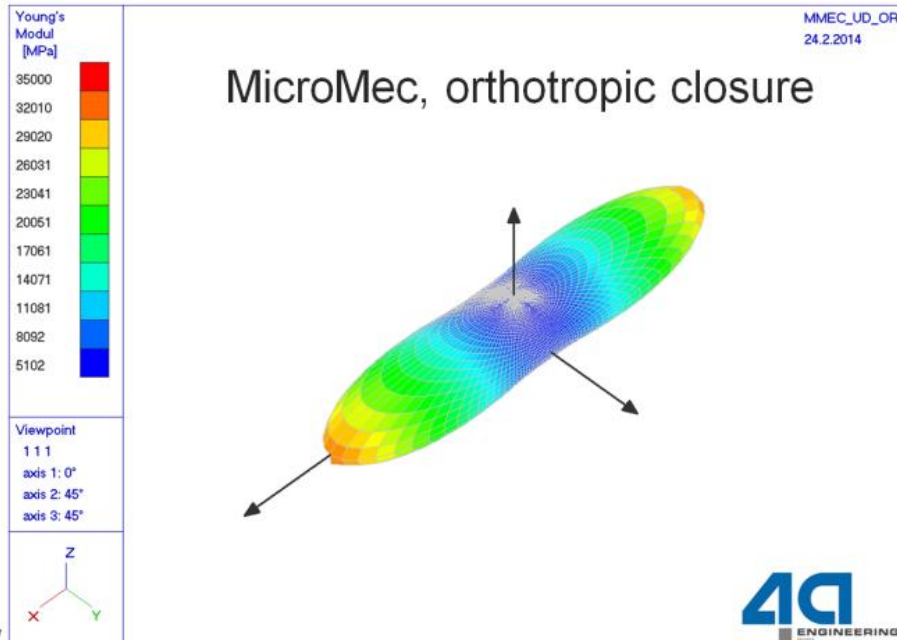

- Comparison by University of Leoben between Digimat-MF and 4a micromec
- User material (orthotropic elastic visco-plastic including failure)

No.	Elastic	Plastic	Damage	Strain rate	Failure	
2	Ortho / Anisotropic	None	None	None	*MAT_ADD_EROSION	SFRT / LFRT
24	Isotropic	Mises	None	Plasticity	*MAT_ADD_EROSION	
103	Isotropic	Hill	None	Plasticity	*MAT_ADD_EROSION	
108	Orthotropic	Hill	None	None	*MAT_ADD_EROSION	
157	Anisotropic	Hill	None	Plasticity	*MAT_ADD_EROSION	
215	<b>*MAT_4a_micromec in development: Model based on MORI TANAKA MEANFIELD</b>					
22	Orthotropic	None	None	None	Orientation dependent	Carbon, Glass, Kevlar endless & fabric
54/55	Orthotropic	None	Elastic Orthotropic	Strength	Chang-Chang/ Tsai-Wu Orientation dependent	
58	Orthotropic	None	Elastic Orthotropic	Strength, Stiffness	mod. Hashin Orientation dependent	
158	Orthotropic	None	Elastic Orthotropic	Visco-elasticity	Orientation dependent	
261	Orthotropic	None	Elastic Orthotropic	None	failure Pinho (Puck) Orientation dependent	
262	Orthotropic	None	Elastic Orthotropic	None	failure Camanho (Puck) Orientation dependent	

## USERMAT → Micro mechanic based material models



- **\*MAT\_157** → phenomenological model based on composites stresses
- **\*MAT\_4a\_micromec (\*MAT\_215)**
  - Current development / available Q4/2016
  - Based on 4a\_micromec
  - In each simulation cycle
    - **Composite stress → matrix and fiber stress**
    - Matrix: isotropic elastic viscoplastic
    - Fiber: (transversal) isotropic elastic
  - Advantage
    - Material behavior **local** defined **through mapped fiber orientation**
    - Failure criteria based on matrix or fiber

- Hill plasticity → „extended“ von Mises

$$\sigma_{\text{eq}} = \sqrt{F(\sigma_{22} - \sigma_{33})^2 + G(\sigma_{33} - \sigma_{11})^2 + H(\sigma_{11} - \sigma_{22})^2 + 2L\sigma_{23}^2 + 2M\sigma_{31}^2 + 2N\sigma_{12}^2}$$

$$F = \frac{(\sigma^0)^2}{2} \left( \frac{1}{\bar{\sigma}_{22}^2} + \frac{1}{\bar{\sigma}_{33}^2} - \frac{1}{\bar{\sigma}_{11}^2} \right) = \frac{1}{2} \left( \frac{1}{R_{22}^2} + \frac{1}{R_{33}^2} - \frac{1}{R_{11}^2} \right), \quad L = \frac{3}{2} \left( \frac{\tau^0}{\bar{\sigma}_{23}} \right)^2 = \frac{3}{2R_{23}^2},$$

$$G = \frac{(\sigma^0)^2}{2} \left( \frac{1}{\bar{\sigma}_{33}^2} + \frac{1}{\bar{\sigma}_{11}^2} - \frac{1}{\bar{\sigma}_{22}^2} \right) = \frac{1}{2} \left( \frac{1}{R_{33}^2} + \frac{1}{R_{11}^2} - \frac{1}{R_{22}^2} \right), \quad M = \frac{3}{2} \left( \frac{\tau^0}{\bar{\sigma}_{13}} \right)^2 = \frac{3}{2R_{13}^2},$$

$$H = \frac{(\sigma^0)^2}{2} \left( \frac{1}{\bar{\sigma}_{11}^2} + \frac{1}{\bar{\sigma}_{22}^2} - \frac{1}{\bar{\sigma}_{33}^2} \right) = \frac{1}{2} \left( \frac{1}{R_{11}^2} + \frac{1}{R_{22}^2} - \frac{1}{R_{33}^2} \right), \quad N = \frac{3}{2} \left( \frac{\tau^0}{\bar{\sigma}_{12}} \right)^2 = \frac{3}{2R_{12}^2},$$

# Material models in LS-DYNA

\*MAT\_157 → \*INITIAL\_STRESS\_SHELL(SOLID)

## \*MAT\_157: Selective mapping IHIS

FLAG	Description	Variables	#
$a_0$	Material directions	$q_{11}, q_{12}, q_{13}, q_{31}, q_{32}, q_{33}$	6
$a_1$	Anisotropic stiffness	$C_{ij}$	21
$a_2$	Anisotropic constants	$F, G, H, L, M, N$	6
$a_3$	Stress-strain curve	$LCSS$	1

## \*INITIAL\_STRESS\_SOLID: NHISV

- in addition to 6 stress values and eps NHISV history can be initialized
- NHISV must correspond to the  $a_i$  that define IHIS in \*MAT\_157

$$NHISV = 6a_0 + 21a_1 + 6a_2 + 1a_3$$

# Material models in LS-DYNA

\*MAT\_157 material

- material model based on **composites properties**

description	variables	Number of variables	dependencies
anisotropic stiffness	Cij	21	$C_{ij}(a_{ij}, \varphi, C^M, C^F)$
Hill plasticity	3D: F, G, H, L, M, N 2D: r00, r45, r90	6	$f(a_{ij}, \varphi, \sigma^M, \sigma^F)$
stress-strain curve	Loadcurve	3	$f(a_{ij}, \varphi)$
failure	Loadcurve	6	$f(a_{ij}, \varphi)$

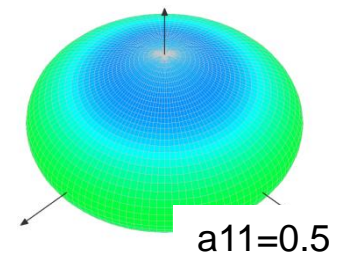
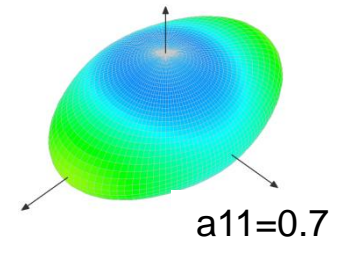
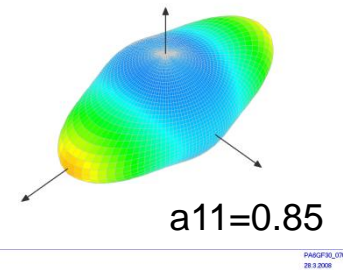
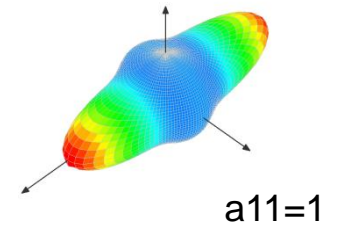

- Not possible to generate samples with **explicit defined and varying  $a_{ij}$**
- Hard to characterize, too many possibilities in  $a_{ij}$

→ **Micro mechanical model is needed**



# MAT\_157 - micro mechanic models as key enabler

Consider each direction in one material model

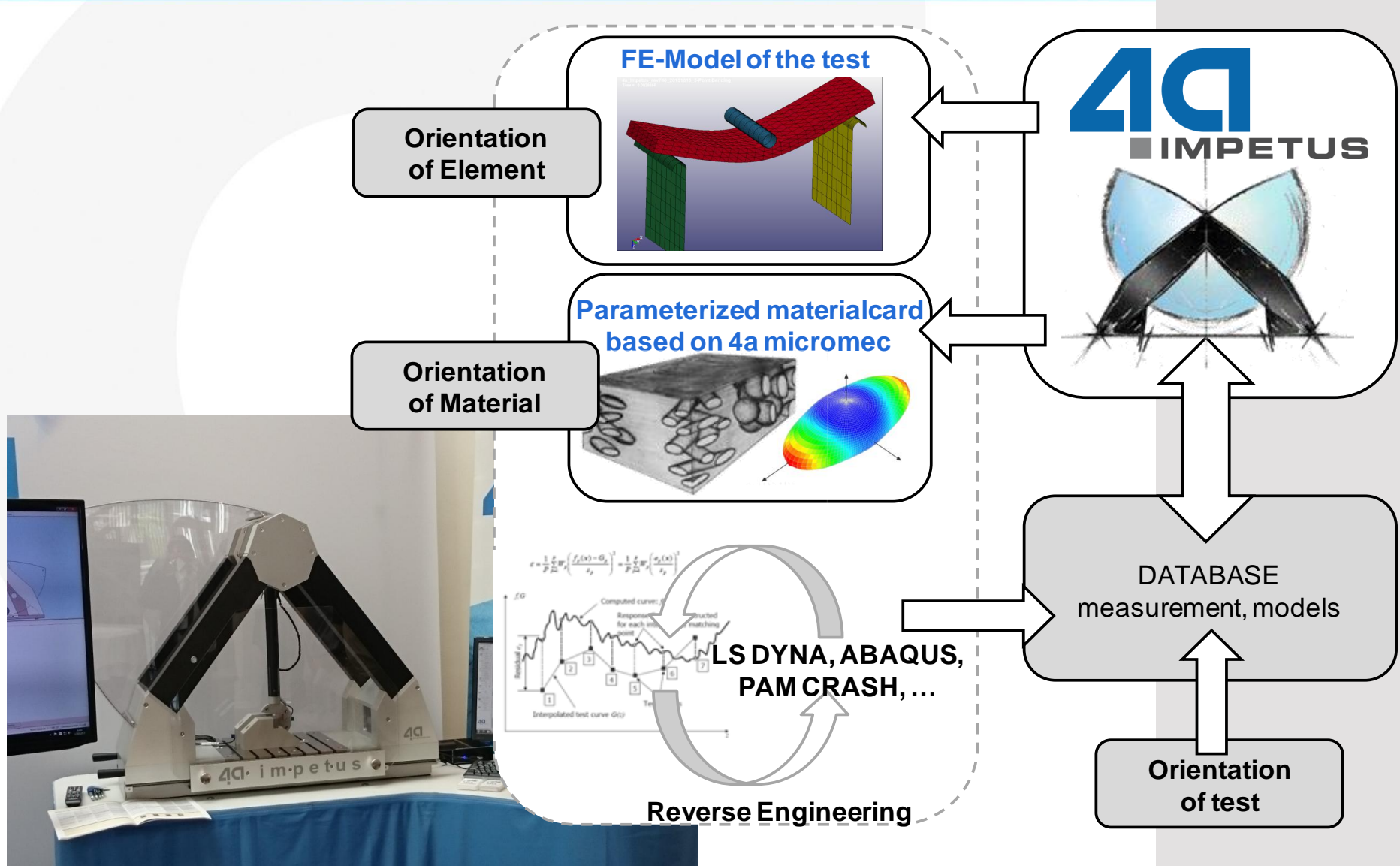

Consider each direction in one material model

e.g. PP LGF30

- micro mechanics  
based on **Fiber & Matrix** properties

**Composite elasticity** → orthotropic  $E_1, E_2, E_3, \nu_{12}, \nu_{13}, \nu_{23}, G_{12}, G_{13}, G_{23}$

**Composite plasticity** → HILL coefficient  $F, G, H, L, M, N$

- **Reverse Engineering**

- hardening: Bilinear → **2 parameters**
- strainrate: Johnson Cook → **1 parameter**
- failure: DIEM → **equivalent HILL strain**

## MAT\_ADD\_EROSION: DIEM with DUCTILE CRITERION

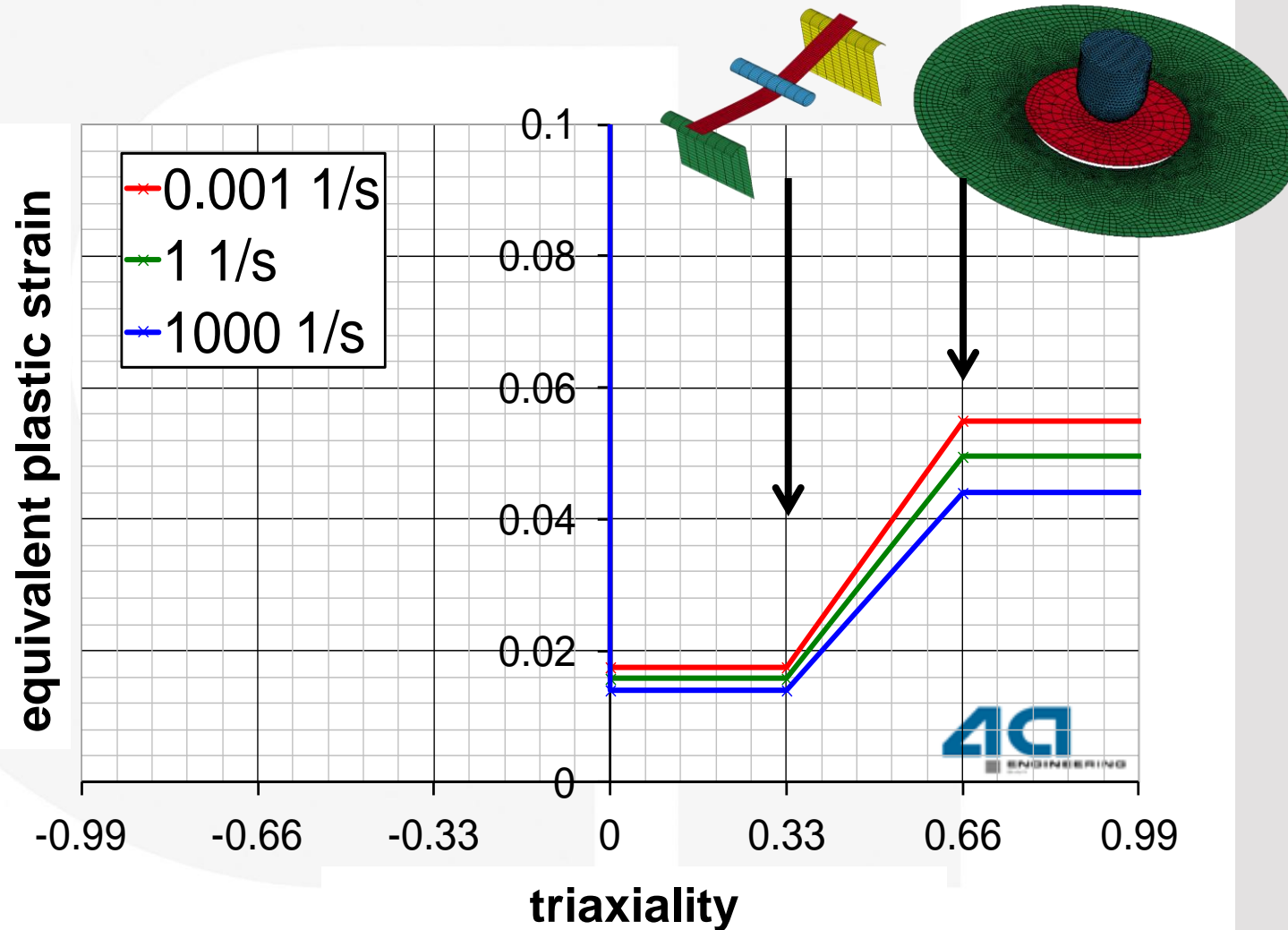

# MAT\_157 - micro mechanic models as key enabler

Current 4a impetus 3.4 alpha version

160223\_006    Material    Designvariablen    Layers

<input type="checkbox"/> Strain rate dependency	Table
<input type="checkbox"/> Strain rate dependency	Johnson Cook
<input type="checkbox"/> Micromec	User defined
<input type="checkbox"/> Matrix	
Density of the matrix	900
E-Modulus	1500
Poisson's ratio	0.3
Yield strength	15
Strength at Break	17
Failure strain	0.05
<input type="checkbox"/> Fiber	
Fillerlength	1000
Fillerdiameter	20
Phi or Psi	$\varphi$
Phi	12.9
Psi	30.1
Fillermaterial	E-Glas
<input type="checkbox"/> Orientation	
<input type="checkbox"/> Fillerorientationtype	CA lin. OF
Fillerorientationvalue 1	0.6
Fillerorientationvalue 2	0.33

Composite Density	1126 [g/dm <sup>3</sup> ]
c_C11	6172 [MPa]
c_C12	1808 [MPa]
c_C13	1231 [MPa]
c_C14	0 [MPa]
c_C15	0 [MPa]
c_C16	0 [MPa]
c_C22	4135 [MPa]
c_C23	1181 [MPa]
c_C24	0 [MPa]
c_C25	0 [MPa]
c_C26	0 [MPa]
c_C33	2616 [MPa]
c_C34	0 [MPa]
c_C35	0 [MPa]
c_C36	0 [MPa]
c_C44	1554 [MPa]
c_C45	0 [MPa]
c_C46	0 [MPa]
c_C55	888.6 [MPa]
c_C56	0 [MPa]
c_C66	957.5 [MPa]
y_r00	1 [1]
y_r45	0.5105 [1]
y_r90	0.2665 [1]
y_scalematrix0	3.076 [1]



# MAT\_157 - micro mechanic models as key enabler

Current 4a impetus 3.4 alpha version

Name	Start	const...	Description
^ GroupName: 10_elasticity			
c_C11	MMEC	<input checked="" type="checkbox"/>	constitutive matrix 11
c_C12	MMEC	<input checked="" type="checkbox"/>	constitutive matrix 12
c_C13	MMEC	<input checked="" type="checkbox"/>	constitutive matrix 13
c_C14	MMEC	<input checked="" type="checkbox"/>	constitutive matrix 14
c_C15	MMEC	<input checked="" type="checkbox"/>	constitutive matrix 15
c_C16	MMEC	<input checked="" type="checkbox"/>	constitutive matrix 16
c_C22	MMEC	<input checked="" type="checkbox"/>	constitutive matrix 23
c_C23	MMEC	<input checked="" type="checkbox"/>	constitutive matrix 23
c_C24	MMEC	<input checked="" type="checkbox"/>	constitutive matrix 24
c_C25	MMEC	<input checked="" type="checkbox"/>	constitutive matrix 25
c_C26	MMEC	<input checked="" type="checkbox"/>	constitutive matrix 26
c_C33	MMEC	<input checked="" type="checkbox"/>	constitutive matrix 33
c_C34	MMEC	<input checked="" type="checkbox"/>	constitutive matrix 34
c_C35	MMEC	<input checked="" type="checkbox"/>	constitutive matrix 35
c_C36	MMEC	<input checked="" type="checkbox"/>	constitutive matrix 36
c_C44	MMEC	<input checked="" type="checkbox"/>	constitutive matrix 44
c_C45	MMEC	<input checked="" type="checkbox"/>	constitutive matrix 45
c_C46	MMEC	<input checked="" type="checkbox"/>	constitutive matrix 46
c_C55	MMEC	<input checked="" type="checkbox"/>	constitutive matrix 55
c_C56	MMEC	<input checked="" type="checkbox"/>	constitutive matrix 56
c_C66	MMEC	<input checked="" type="checkbox"/>	constitutive matrix 66

Name	Start	const...	Description
^ GroupName: 10_elasticity			
^ GroupName: 20_yield			
y_0	90	<input checked="" type="checkbox"/>	yield stress
y_scale...	MMEC	<input checked="" type="checkbox"/>	yield scale 11 direction
y_r00	MMEC	<input checked="" type="checkbox"/>	yield hill anisotropy ratio 0°
y_r45	MMEC	<input checked="" type="checkbox"/>	yield hill anisotropy ratio 45°
y_r90	MMEC	<input checked="" type="checkbox"/>	yield hill anisotropy ratio 90°
^ GroupName: 21_hardening			
h_ET	50	<input checked="" type="checkbox"/>	
h_y	90	<input checked="" type="checkbox"/>	
^ GroupName: 31_strainrate			
v_epspkt	0.01	<input checked="" type="checkbox"/>	initial strain rate threshold
v_p	15	<input checked="" type="checkbox"/>	strain rate scale (1/vp)
^ GroupName: 51_failure			
xf_NUM...	0.75	<input checked="" type="checkbox"/>	Number of failed integration points prior to

\* [Click here to add a new row](#)

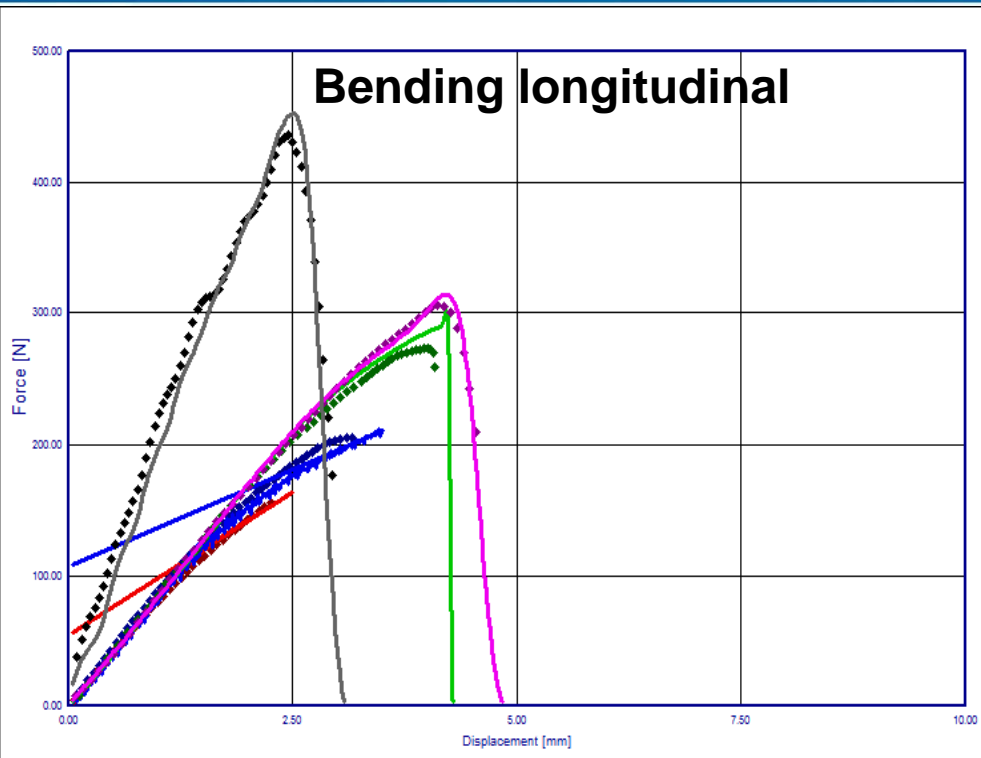

Shell 2mm, Type 16, 5 IP

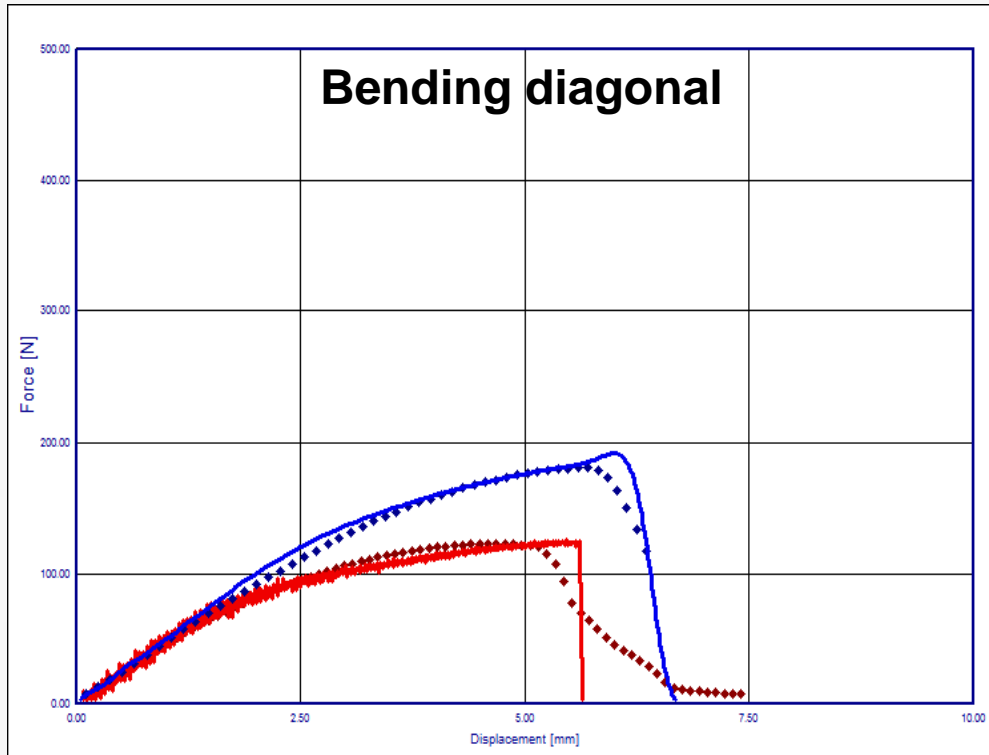

Shell 2mm, Type 16, 5 IP

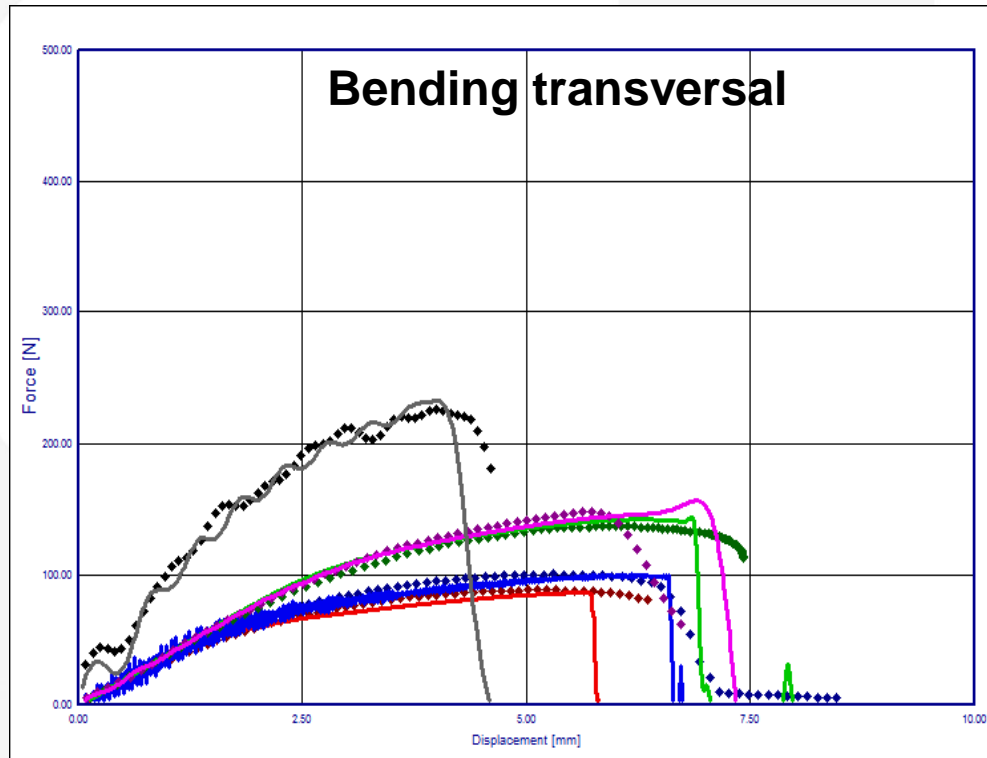

Shell 2mm, Type 16, 5 IP

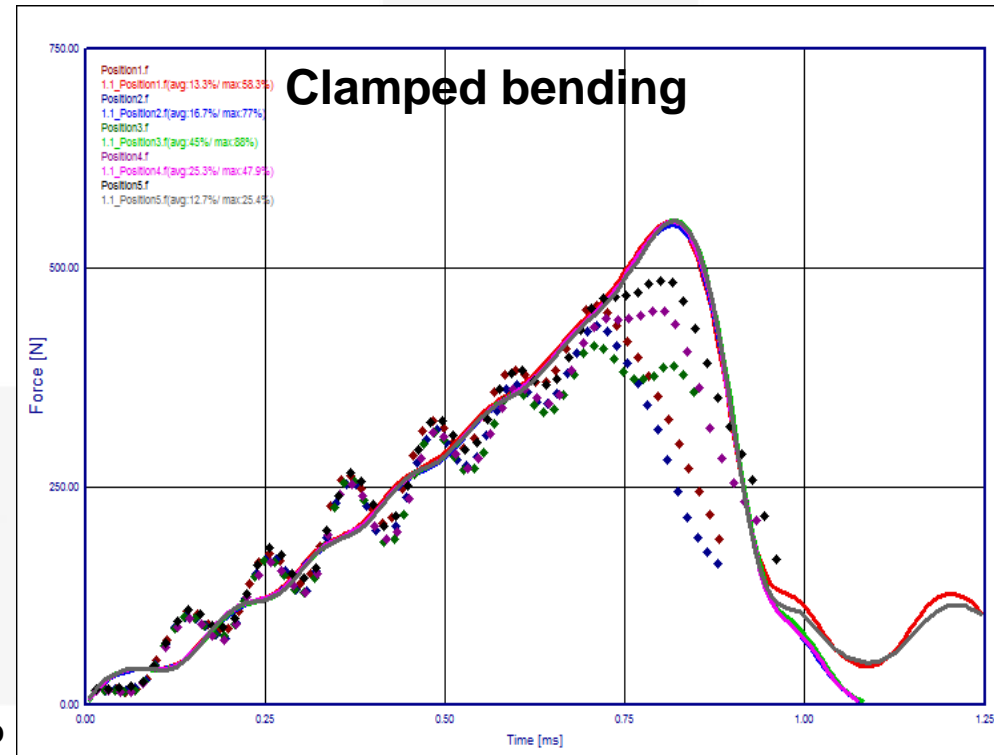

Shell 2mm, Type 16, 5 IP



# MAT\_157 - micro mechanic models as key enabler

Consider each direction in one material model

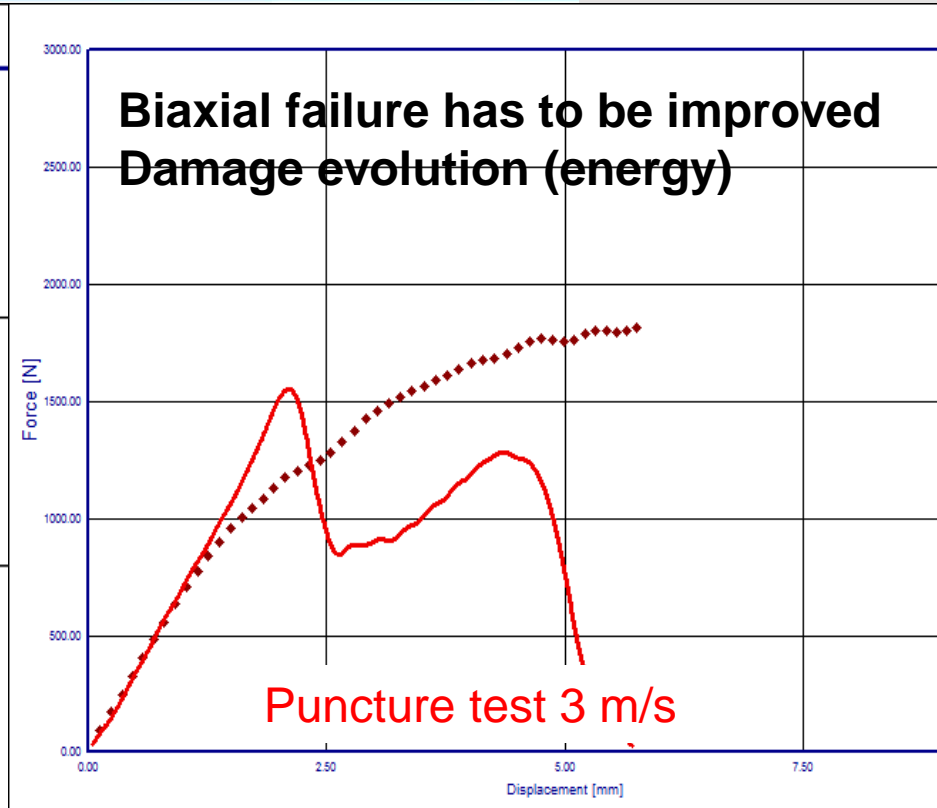
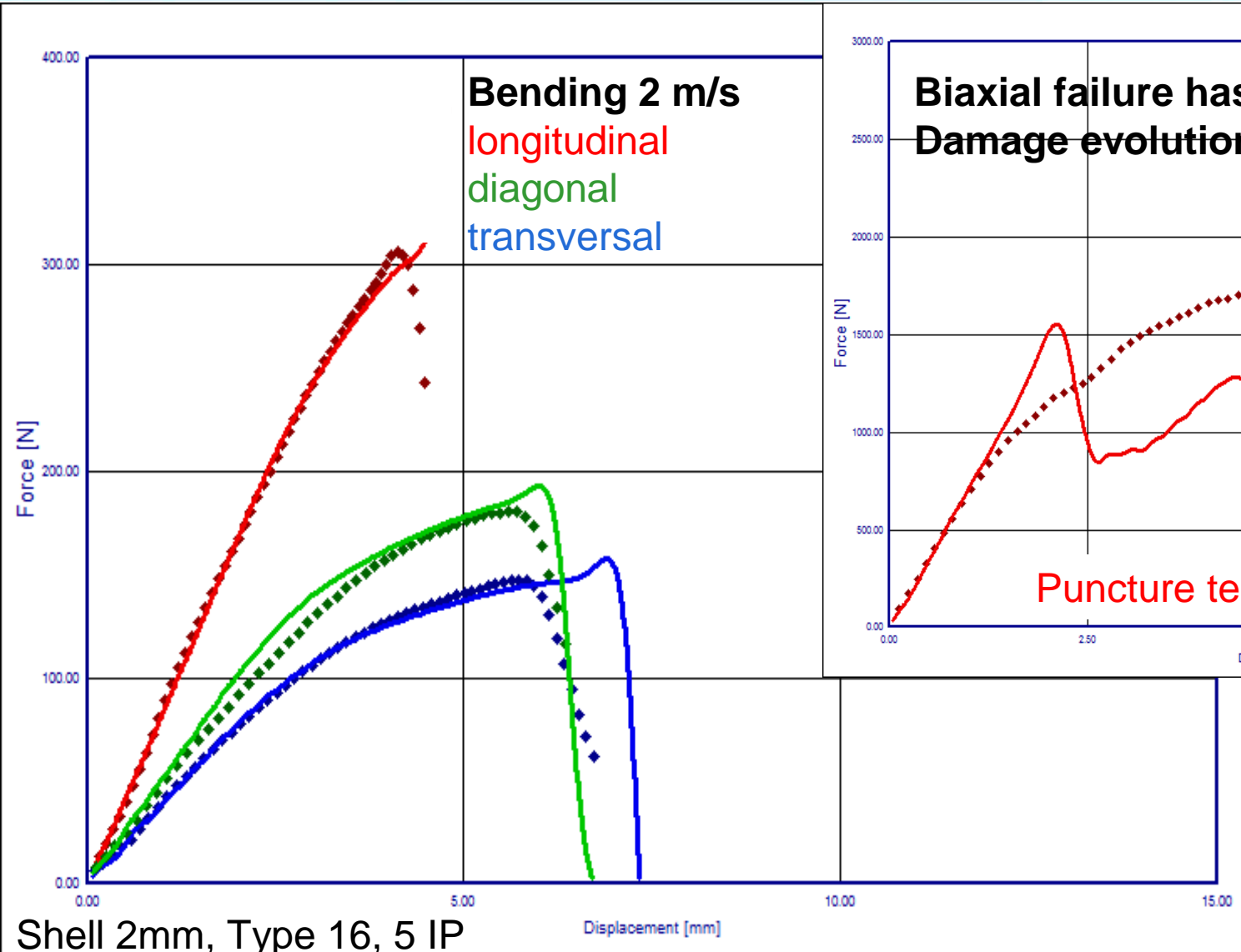

Consider each direction in one material model

## Solid – TET10 (Type 16)

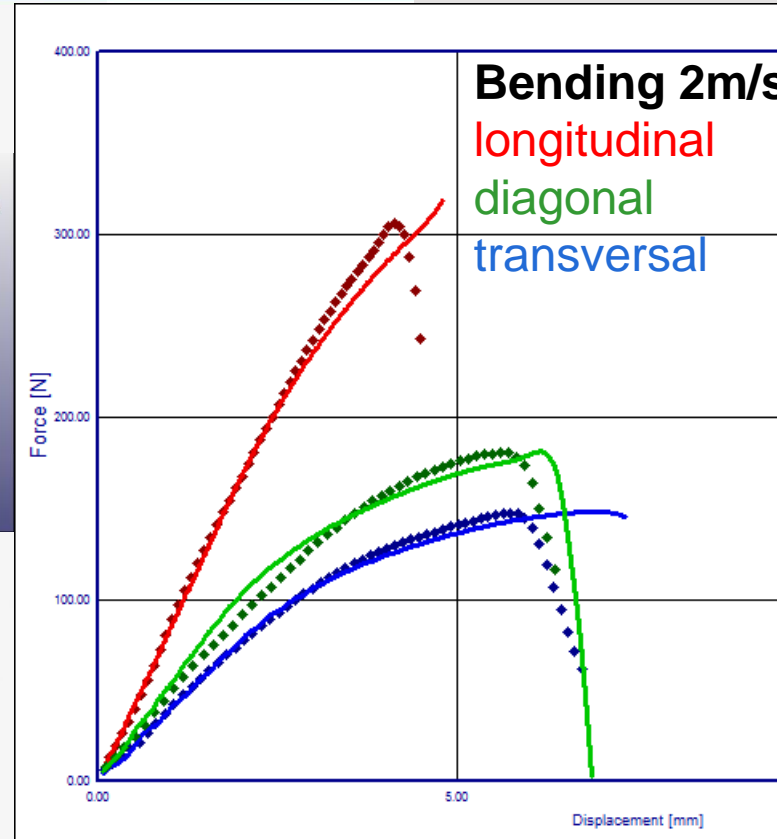
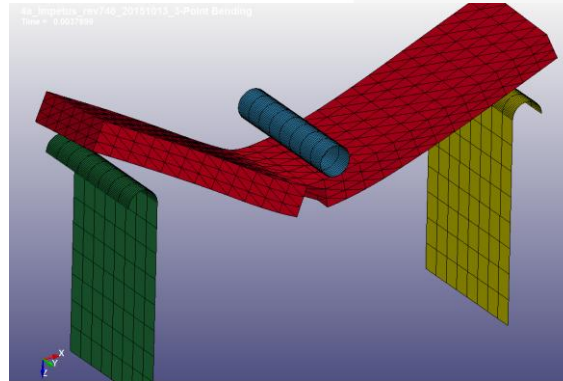
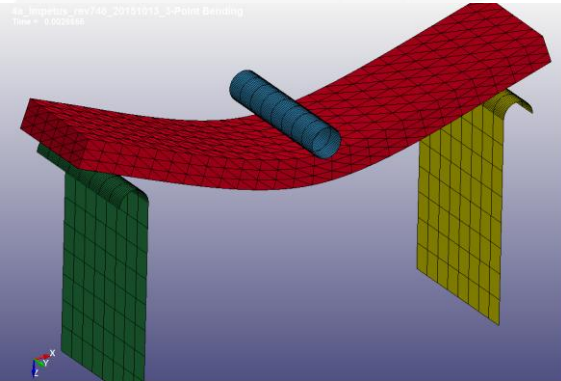

# Simulation process chain

For injection molded parts

[2012Reithofer]

## Injection molding (Moldflow, Moldex, ...)

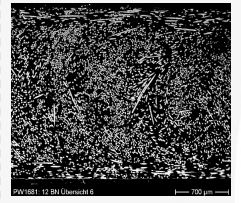

$$a_{ij} = \begin{bmatrix} 0,66 & 0 & 0 \\ 0 & 0,32 & 0 \\ 0 & 0 & 0,02 \end{bmatrix}$$

fiber orientation

## micromechanic modeling (4a micromec, ...)

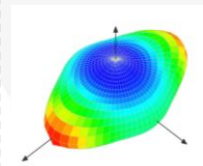

$$c = \begin{bmatrix} c_{11} & c_{12} & c_{13} & c_{14} & c_{15} & c_{16} \\ & c_{22} & c_{23} & c_{24} & c_{25} & c_{26} \\ & & c_{33} & c_{34} & c_{35} & c_{36} \\ & & & c_{44} & c_{45} & c_{46} \\ & & & & c_{55} & c_{56} \\ & & & & & c_{66} \end{bmatrix}$$

anisotropy

## Mapping (4a fibermap, ...)

### In plane mapping

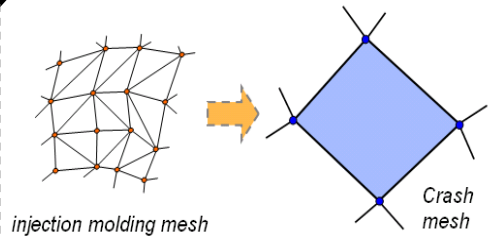

### Mapping in thickness direction

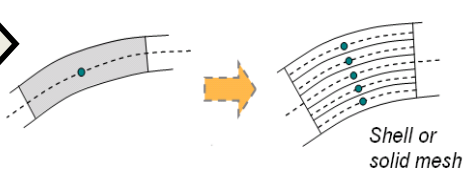

## Crash Simulation (LS-DYNA)

orientations

- \*ELEMENT\_SHELL\_BETA
- \*ELEMENT\_SHELL\_COMPOSITE
- \*INITIAL\_STRESS\_SHELL(SOLID)
- \*ELEMENT\_SOLID\_ORTHO

standard material models

- \*MAT\_(ANISO)TROPIC\_ELASTIC
- \*MAT\_ANISOTROPIC\_ELASTIC\_PLASTIC



# Simulation process chain

## 4a fibermap - mapping

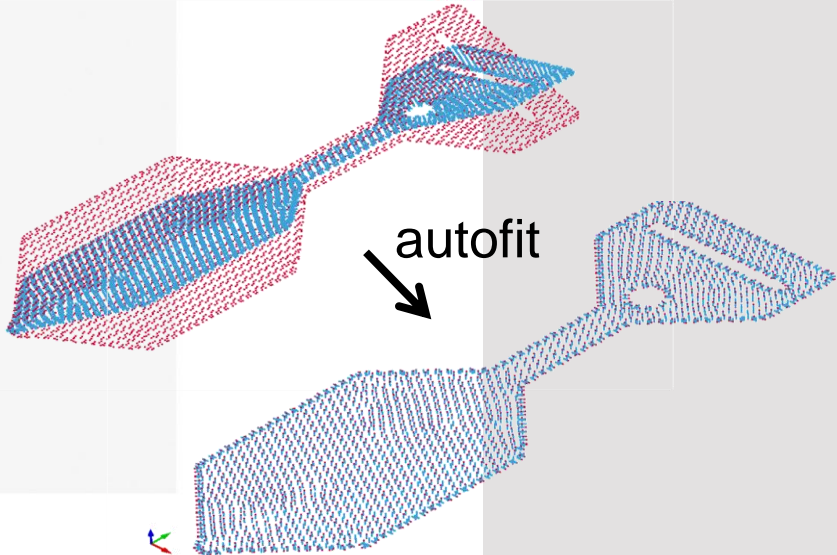
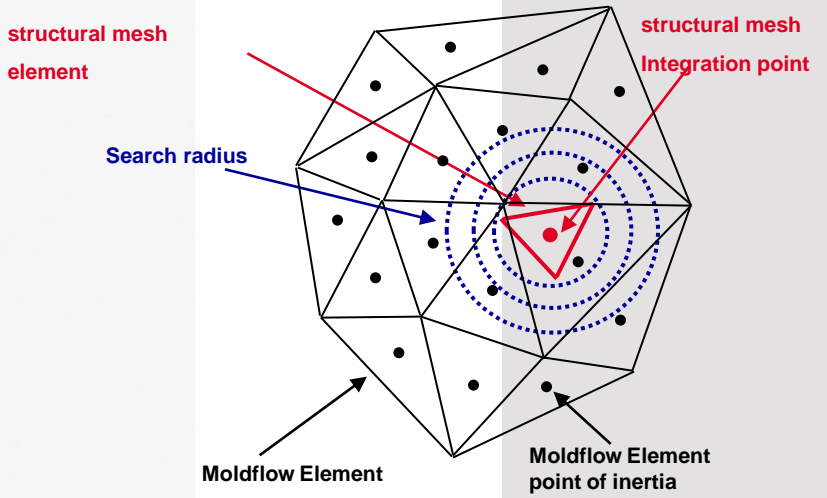
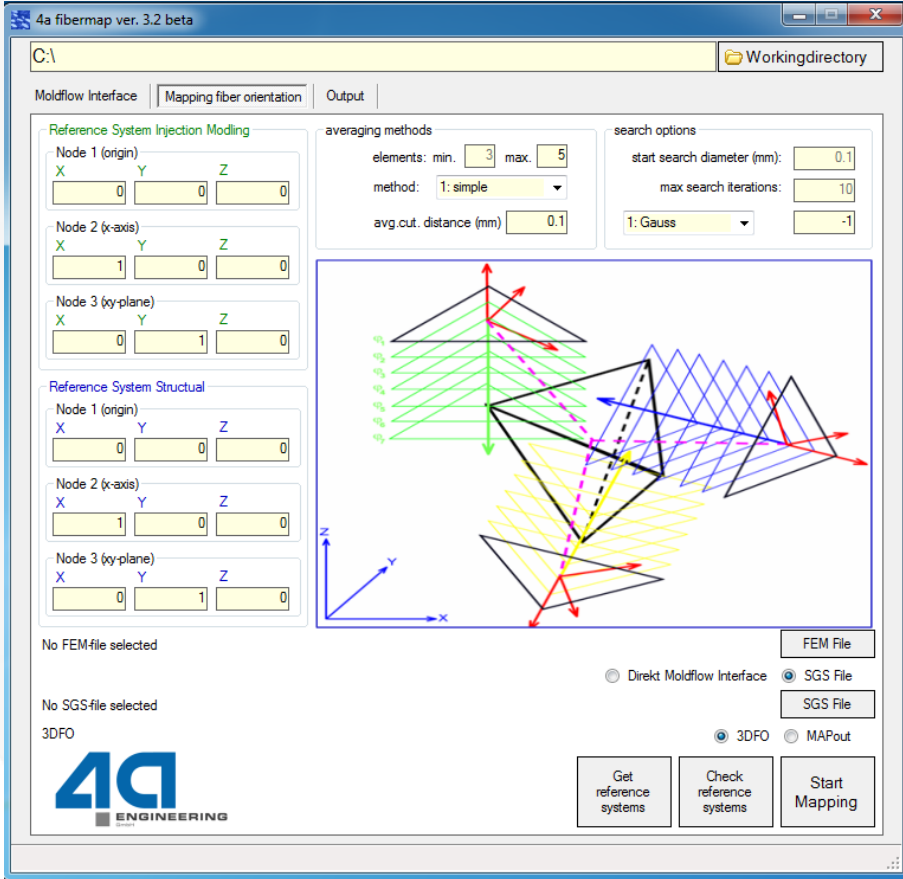

- Moldex3D®- fiber orientation
- Autodesk Moldflow® - fiber orientation and further results can be mapped

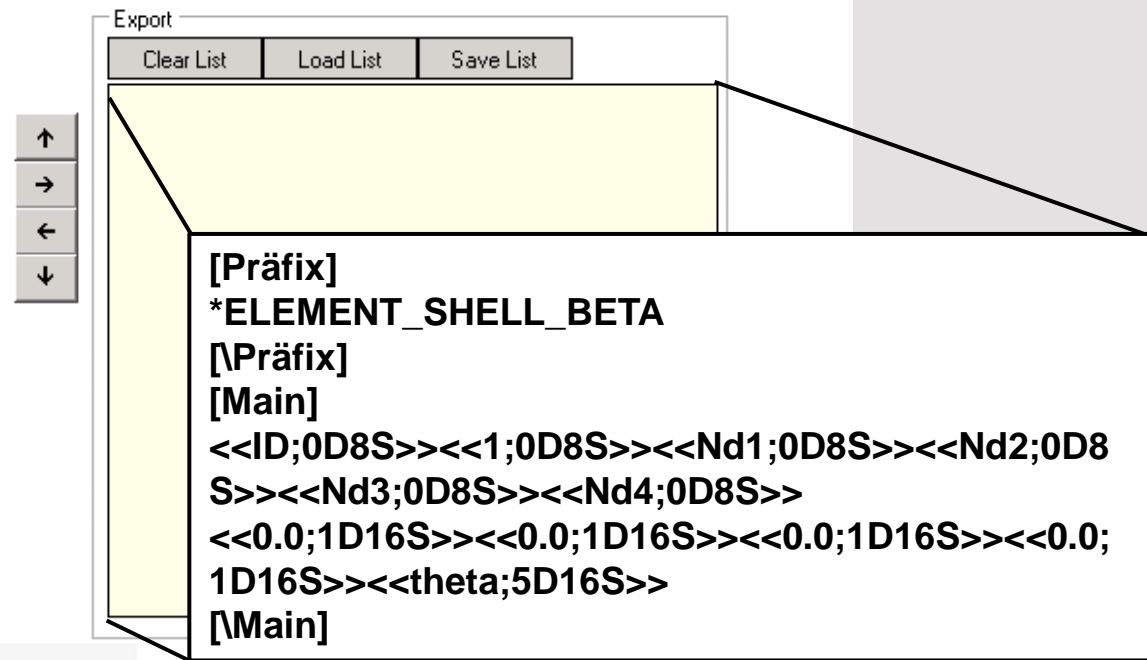
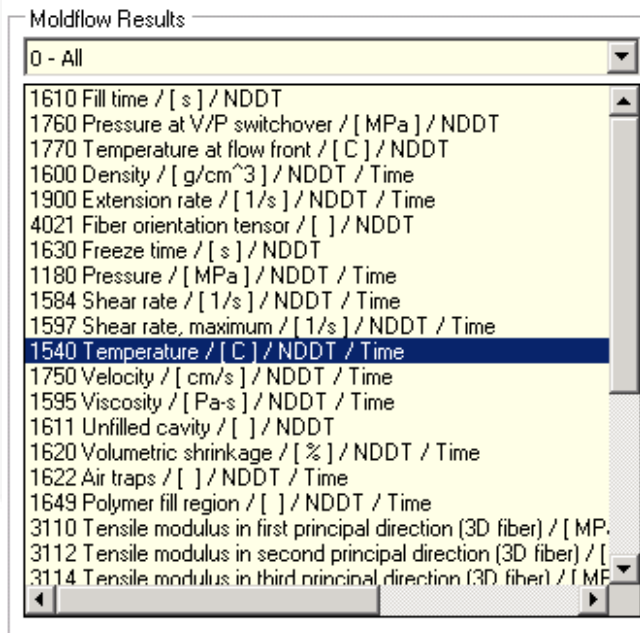



[2012Gramling]

### Process simulation

#### Filling

Fill time  
= 1.736[s]

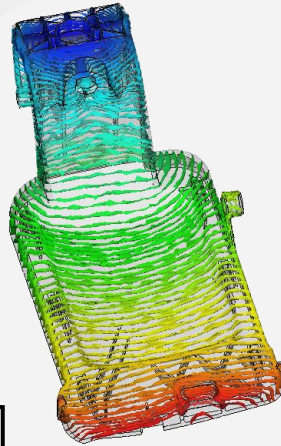

#### Fiber orientation

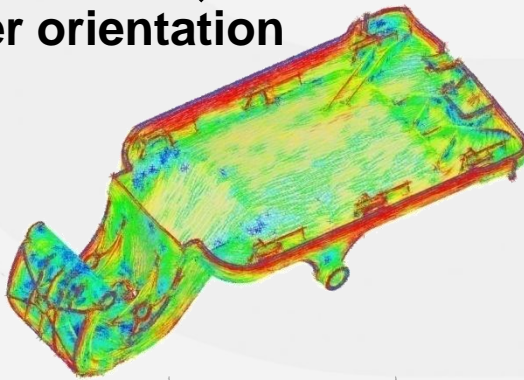

Scale (100 mm)

Autodesk

### Mapping

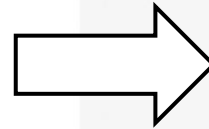
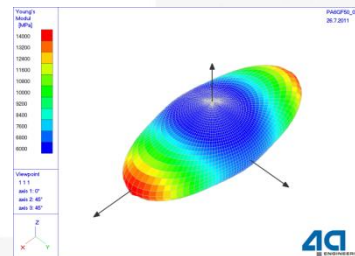

### local anisotropy

### Structural simulation bending

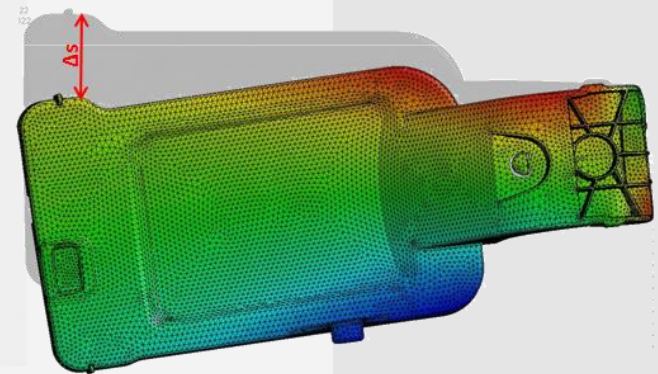
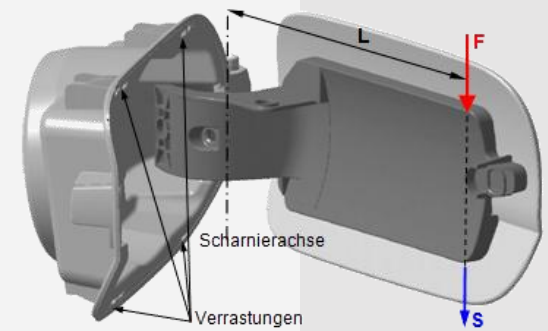

# Case study Nutini Box

Using \*MAT\_157

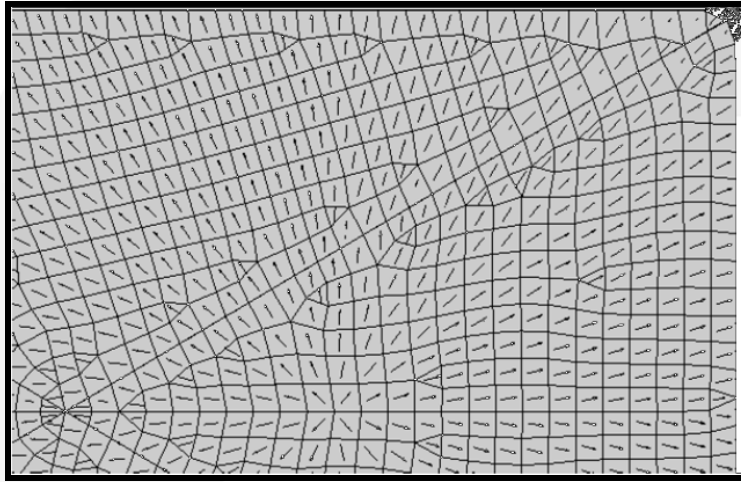

[2014Jennrich]

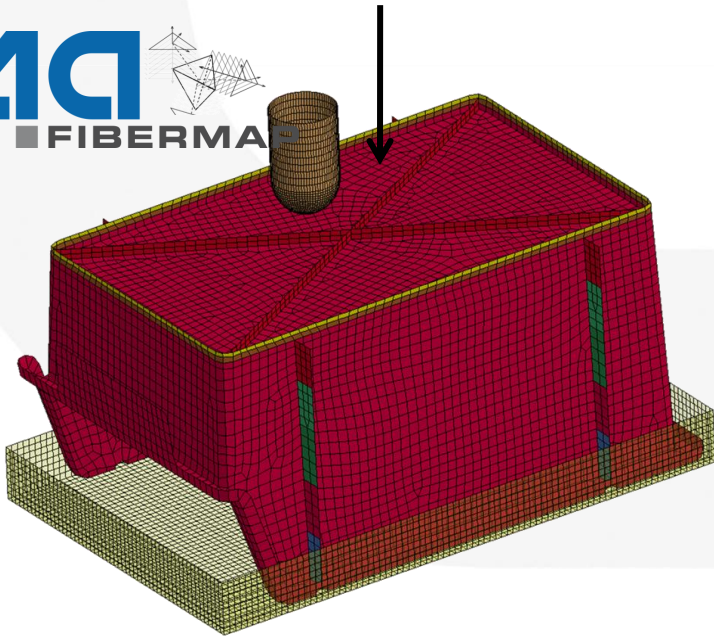
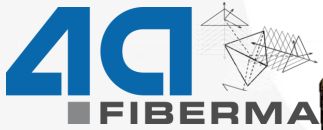

# Case study Doublecrossrib

Using \*MAT\_215

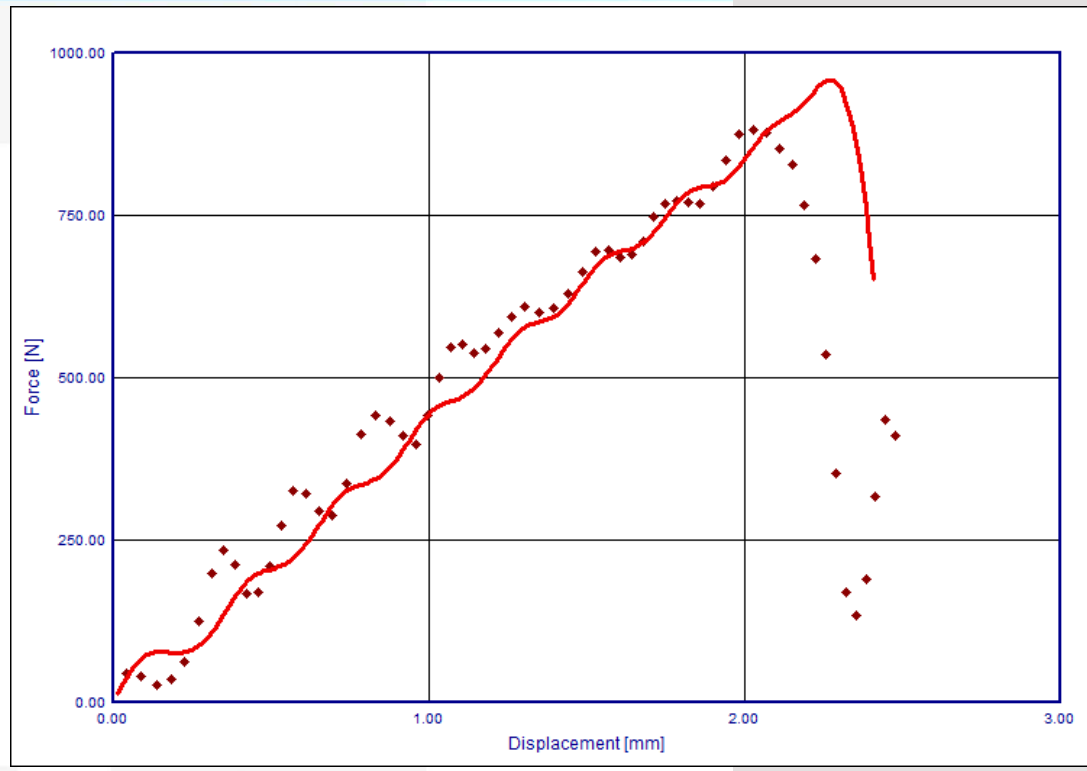
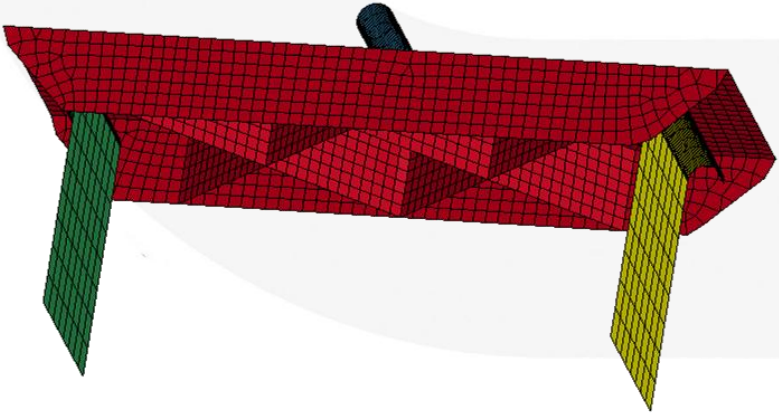
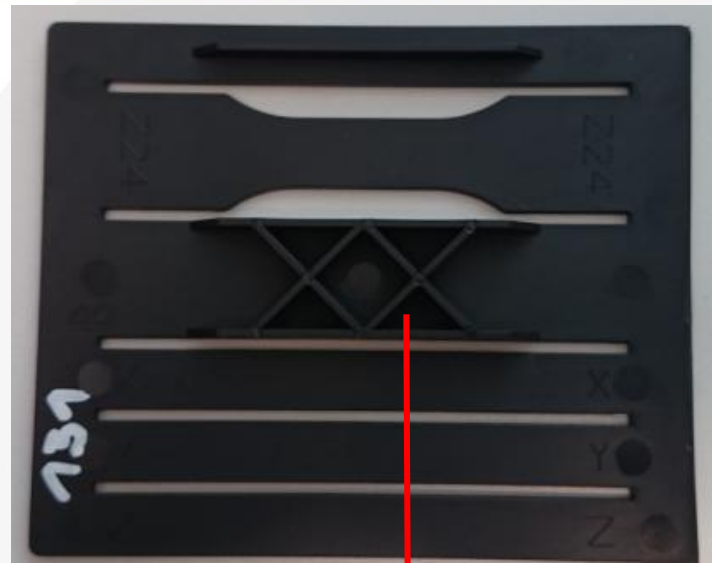



# Conclusion characterization pyramid micro mechanic models as key enabler

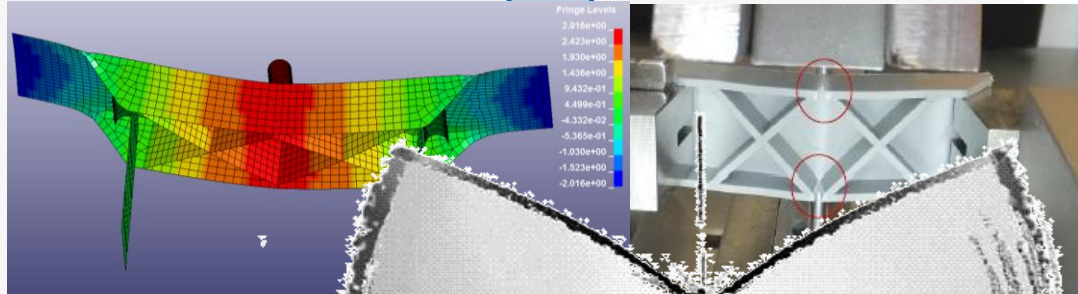

**component  
validation**

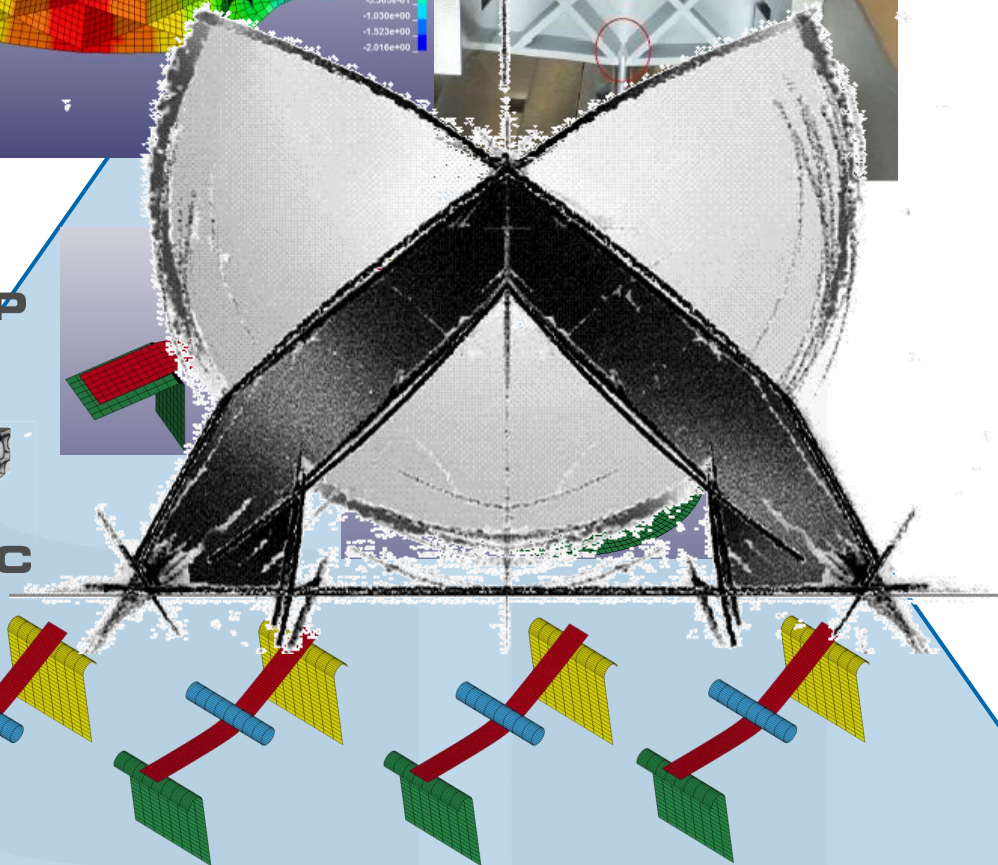
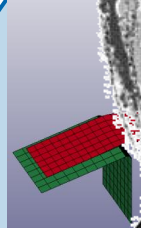

**failure**

**elasticity  
plasticity  
strainrate**

Thank you for your attention!



I N P H Y S I C S W E T R U S T



- [2005Fritz]** M. Fritz, R. Hafellner (4a engineering GmbH) - *Anwendungsgerechte Kunststoffcharakterisierung*, 4. LS-DYNA Forum 2005, Bamberg ([Link](#))
- [2008Reithofer]** P. Reithofer, M. Fritz, T. Wimmer (4a engineering GmbH) – *Kurzfaserverstärkte Kunststoffbauteile - Einfluss der prozessbedingten Faserorientierung auf die Strukturmechanik*, 7. LS-DYNA Anwenderforum, Bamberg 2008 ([Link](#))
- [2012Gramling]** M. Gramling (Audi AG), P. Reithofer (4a engineering GmbH) – *Integrative Simulation von kurzfaserverstärkten Thermoplasten am Beispiel einer Tankklappe*, 4a Technologietag, Schladming 2012 ([Link](#))
- [2012Reithofer]** P. Reithofer, B. Jilka, A. Fertschej (4a engineering GmbH) – *4a micromec für die integrative Simulation faserverstärkter Kunststoffe*, 11. LS-DYNA Anwenderforum, Ulm 2012 ([Link](#))
- [2014Haufe]** A. Haufe (DYNAMore GmbH) – *Zum aktuellen Stand der Simulation von Kunststoffen mit LS-DYNA*, 11. 4a Technologietag - 2014 ([Link](#))
- [2014Jennrich]** R. Jennrich, M. Roth, Prof. S. Kolling (Technische Hochschule Mittelhessen)  
C. Liebold (DYNAMore GmbH), G. Weber (Celanese GmbH) – *Experimentelle und numerische Untersuchung eines kurzglasfaserverstärkten Kunststoffes*, 13. LS-DYNA Forum 2014, Bamberg ([Link](#))
- [2014SimuliaManual]** Abaqus Analysis User's Guide 6.14, Simulia - Dassault Systèmes, <http://simulia.custhelp.com>