

excellence in ...
plastics simulation
testing equipment
lightweight products



Generation of abuse simulation models of battery cells and battery packs

Martin Schwab, Robert Kießling

WCCM-APCOM 2022

Testing and Identification



Material



Testing

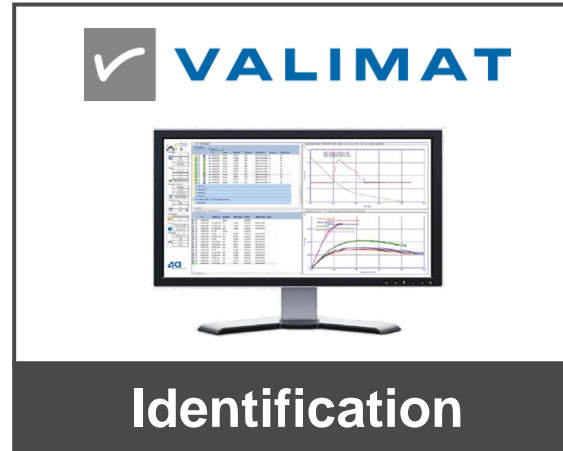

Identification

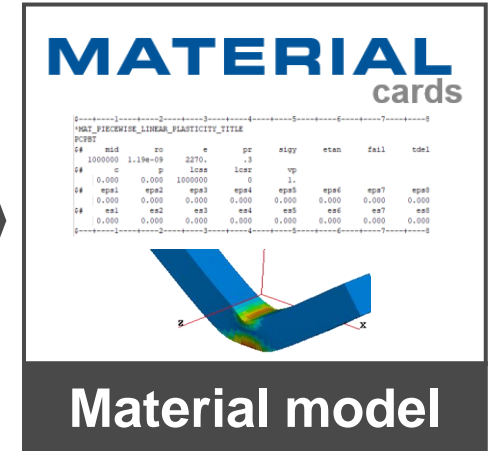

Material model



Battery Cell

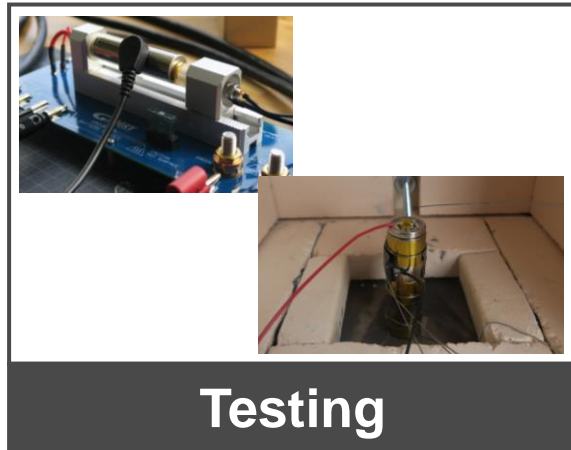

Testing



Identification

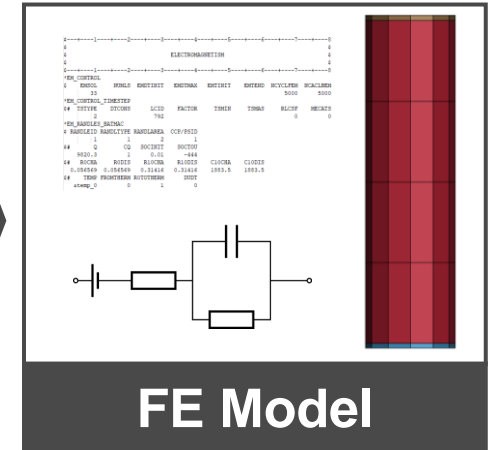

FE Model



Outline

1. Generation of abuse simulation models of a single battery cell using LS Dyna
2. Abuse testing and simulation of a single battery cell
3. Application of a single cell model within the simulation of multi-cell mockups
4. Conclusion and outlook

Generation of abuse simulation models of a single battery cell using LS Dyna

Multiphysics of battery cells

Thermal

ϑ
 λ
 \underline{q}
 T
 p
 k

T

x

k_1 k_2 k_3

Mechanical

T_{11} in MPa
 t in s

F $\underline{\underline{\epsilon}}$ $\underline{\underline{T}}$
 u $\underline{\underline{\sigma}}$

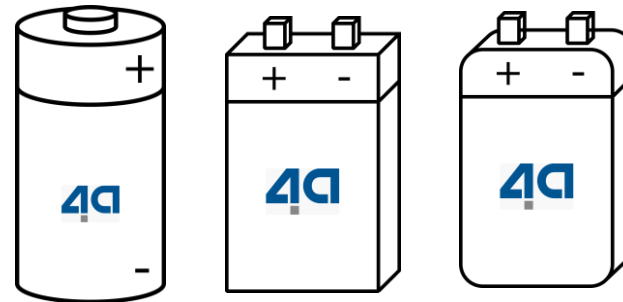

Electromagnetical

R U
 I C
 SOC

Modeling approaches in LS DYNA

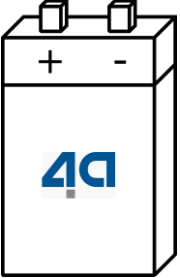
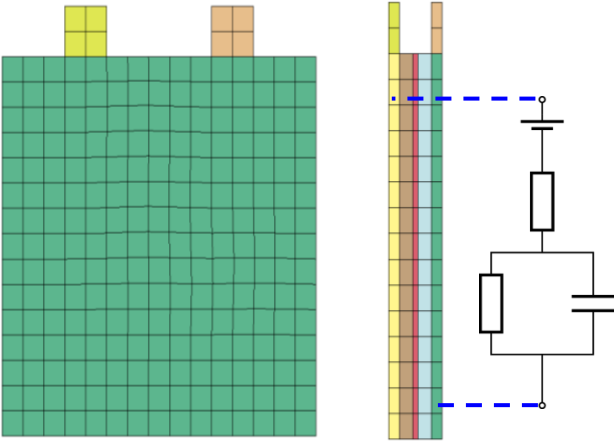
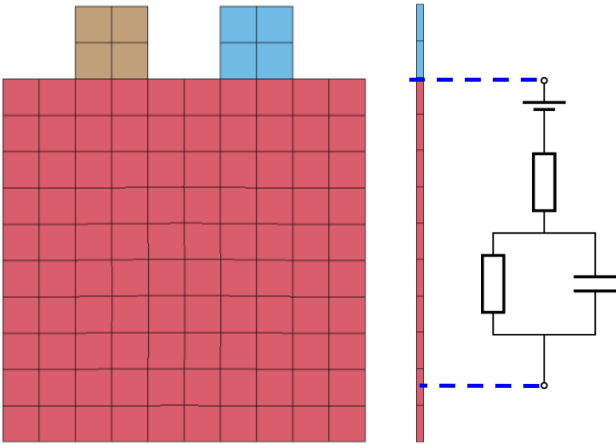
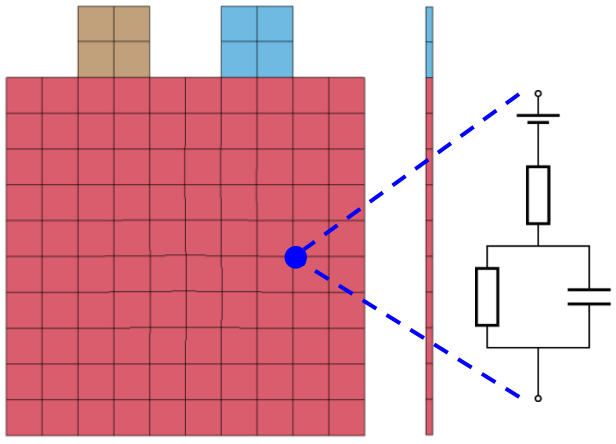
	Solid layer model	Tshell model	Batmac model
			
Keyword	*EM_RANDLES_SOLID	*EM_RANDLES_TSHELL	*EM_RANDLES_BATMAC
Characteristics	<ul style="list-style-type: none"> + Analysis of the different layers is possible - Computational effort 	<ul style="list-style-type: none"> + Beneficial modeling of thin cells - Behavior of the layers can not be analyzed in detail 	<ul style="list-style-type: none"> + Modeling with respect to mechanical and thermal problem - Behavior of the layers can not be analyzed

Electrical modelling and characterization

- electrical behavior is covered by a circuit model

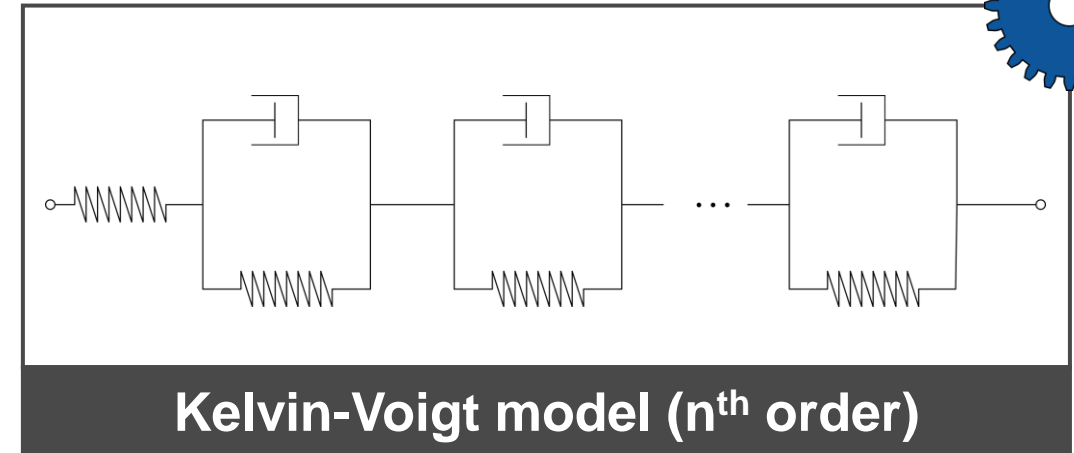
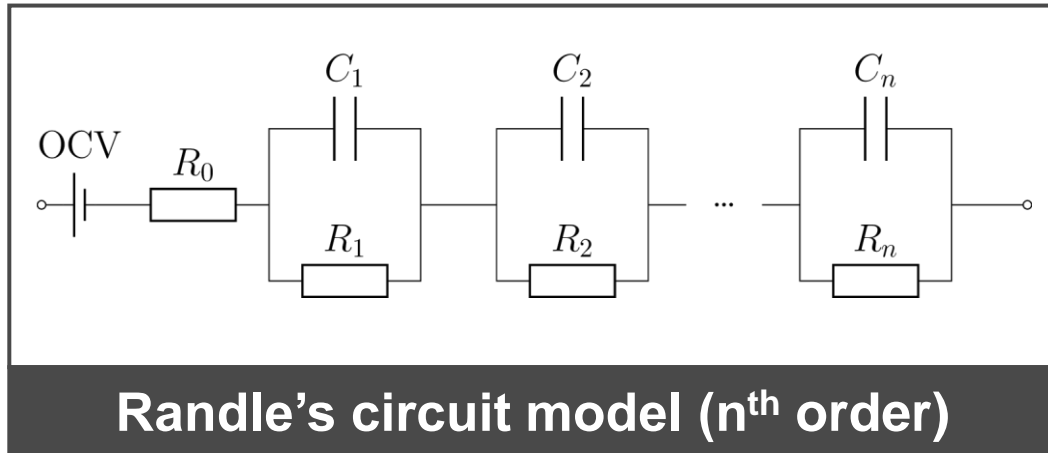

- parameter as well as the OCV-SOC curve are identified from the 4a HPPC test

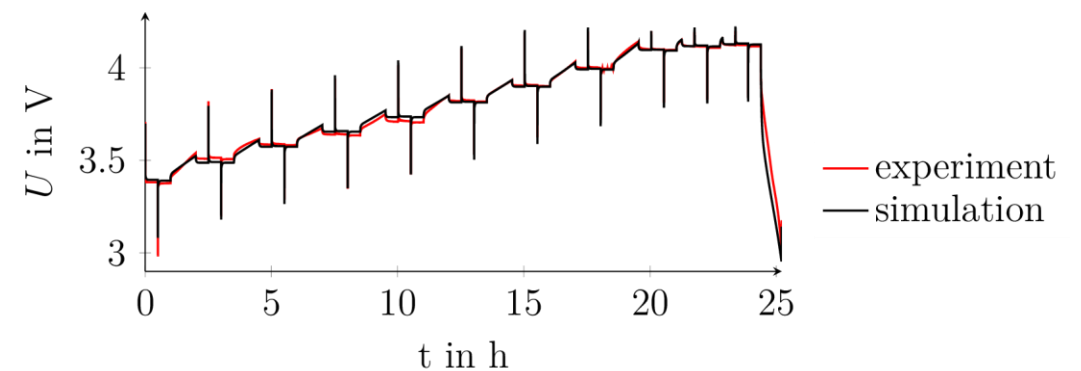
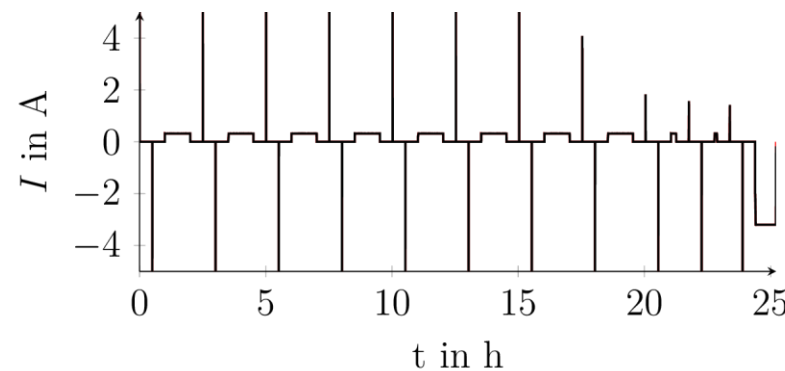
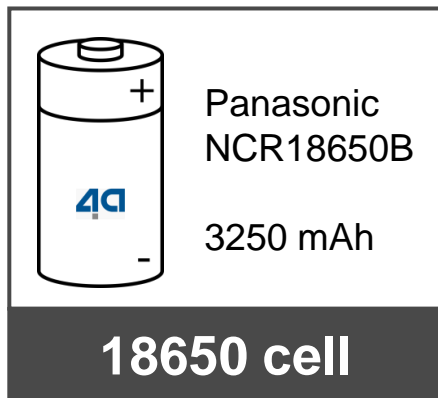

Characteristic of the abuse of a battery cell

- Course of voltage and temperature because of overheating

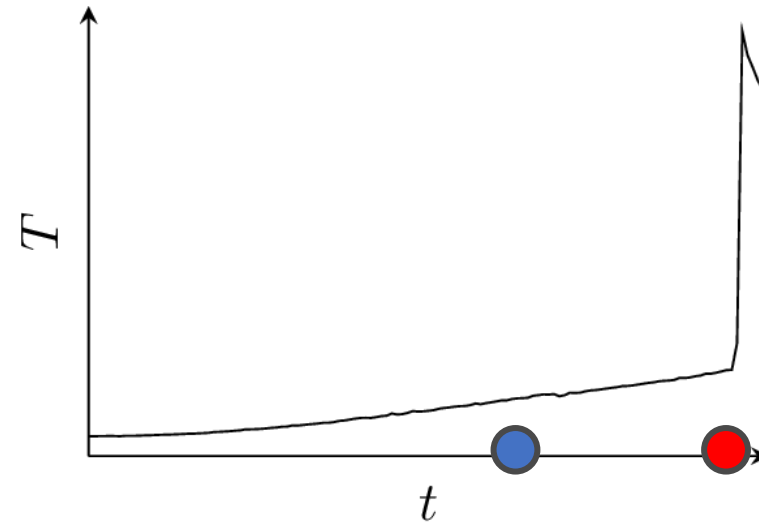
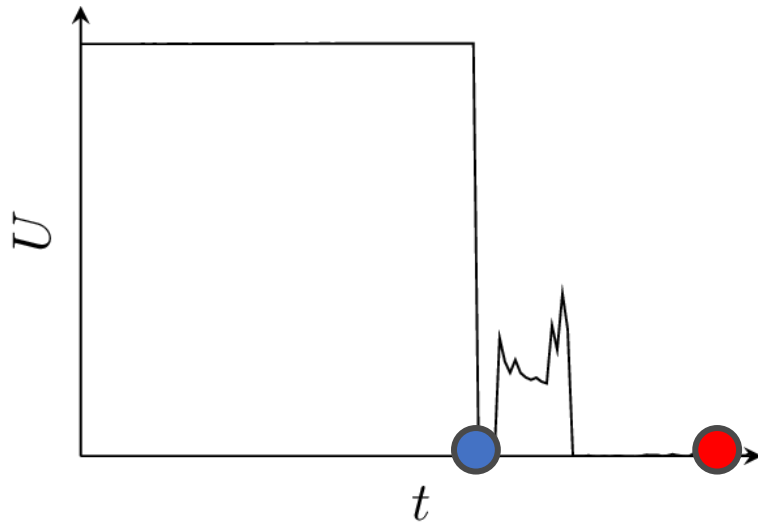

- Characteristic points and effects:
 - **Internal short circuit:** drop of the voltage
 - **Exothermic reaction:** spontaneous increase of the temperature

Abuse simulation of a single cell

- Modeling of the internal short circuit and the exothermal reaction

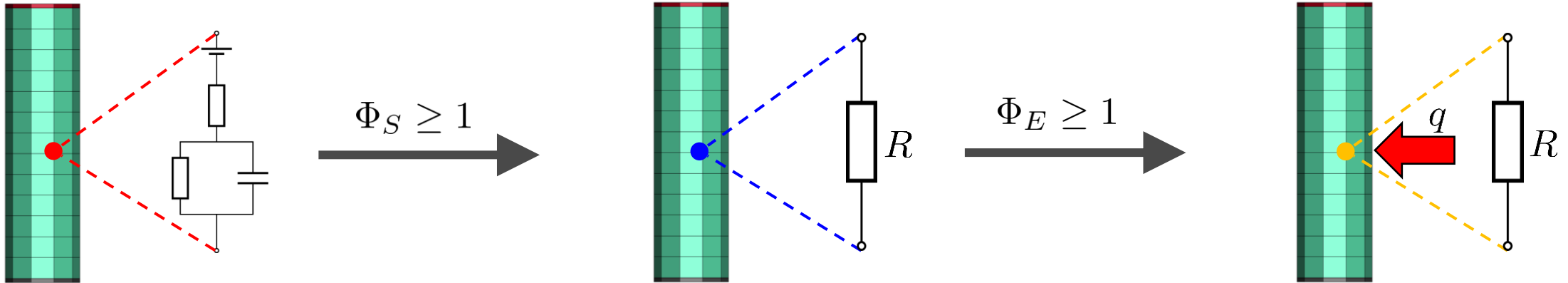

Initiation criterion:

$$\Phi_S (T, \text{SOC}, \underline{\underline{\varepsilon}}) \geq 1$$

Short resistance:

$$R = \text{const.}$$

Internal short circuit

Initiation criterion:

$$\Phi_E (T) \geq 1$$

Additional heat source:

$$q (T)$$

Exothermal reaction

Abuse testing and simulation of a single battery cell

Overheat test of a single battery cell

- Overheating of a fully charged 18650 battery cell (Panasonic NCR18650B) at the bottom
- Measurement of the temperature at the cell as well as in the chamber with 6 thermocouples
- Measurement of the voltage

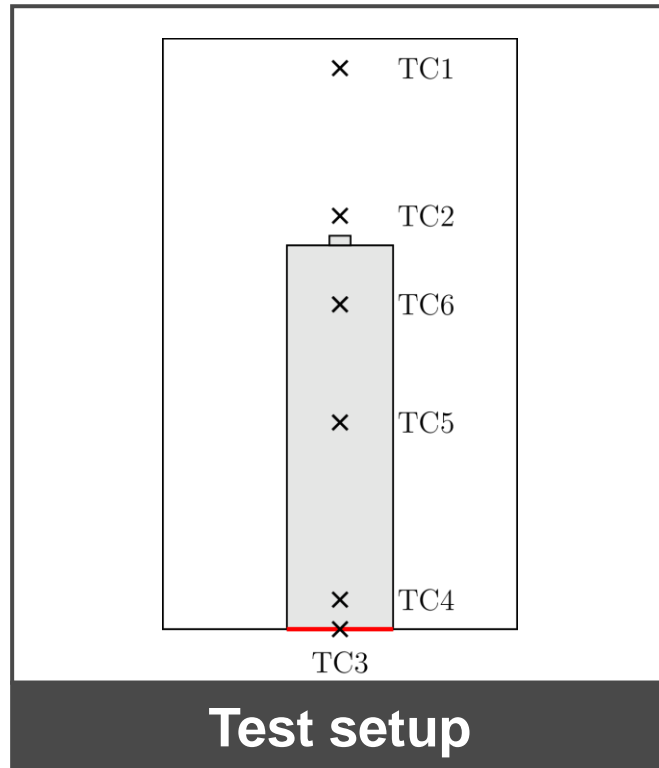

Overheat test of a single battery cell

18650 battery cell

fully charged
overheating at bottom

Overheat test of a single battery cell

Experimental results

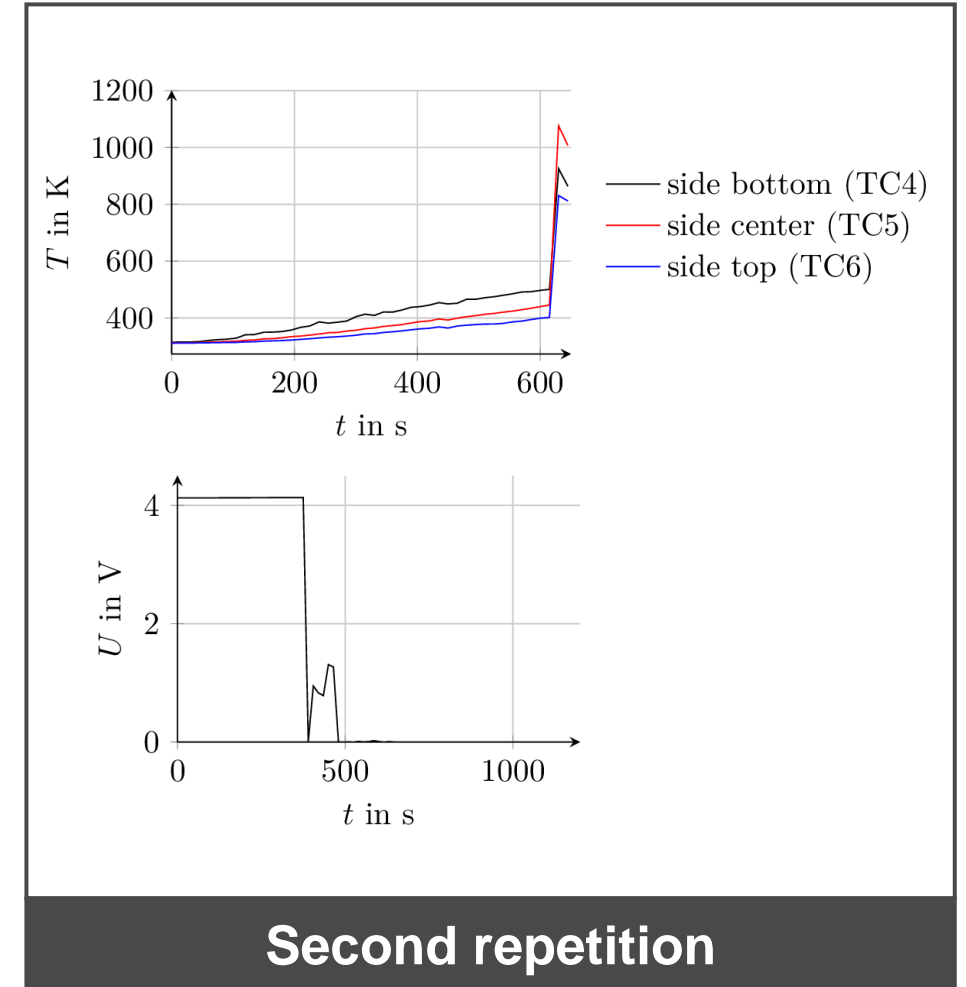
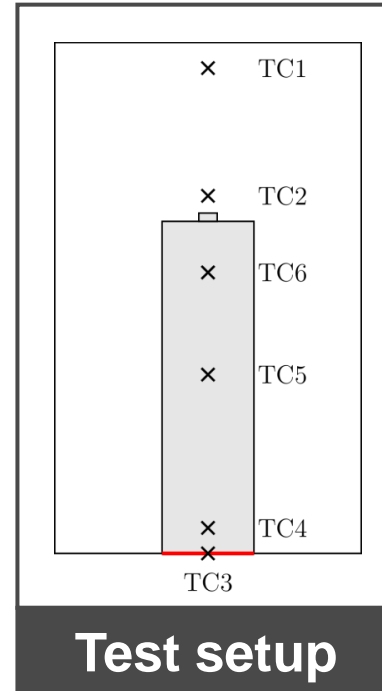
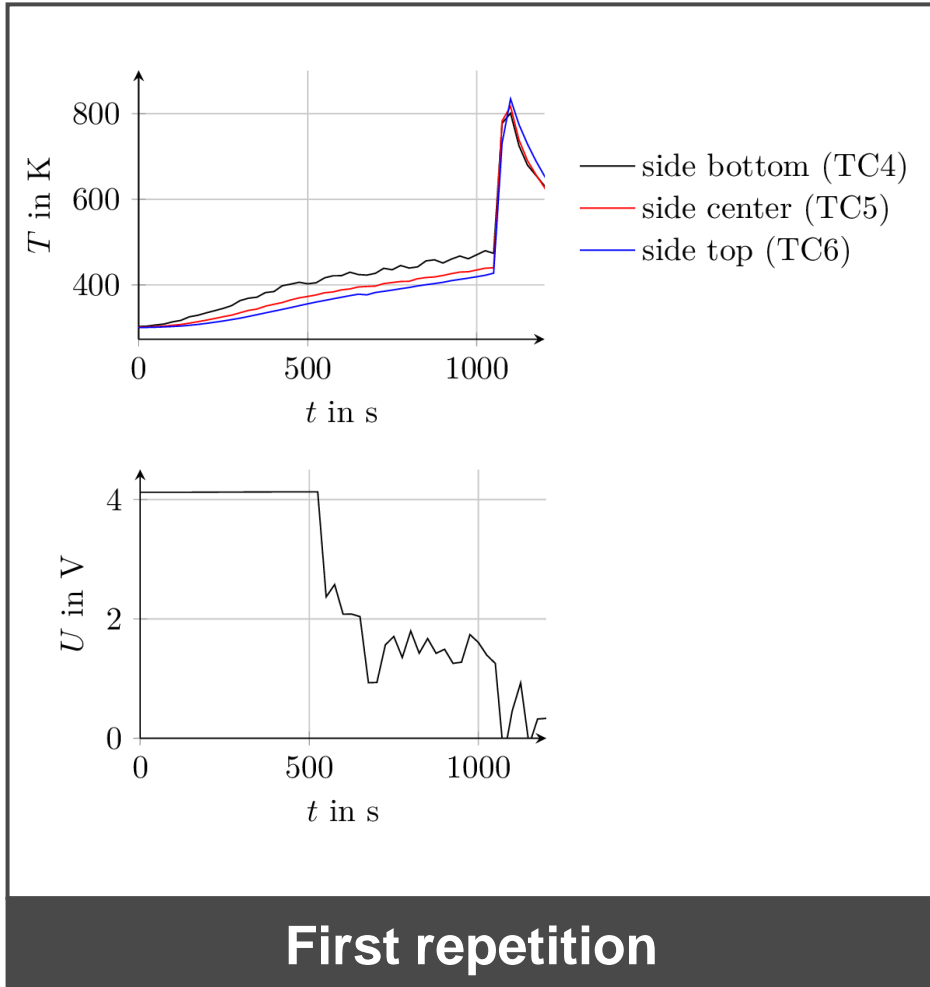

Overheat test of a single battery cell

Comparison of experimental and simulative data

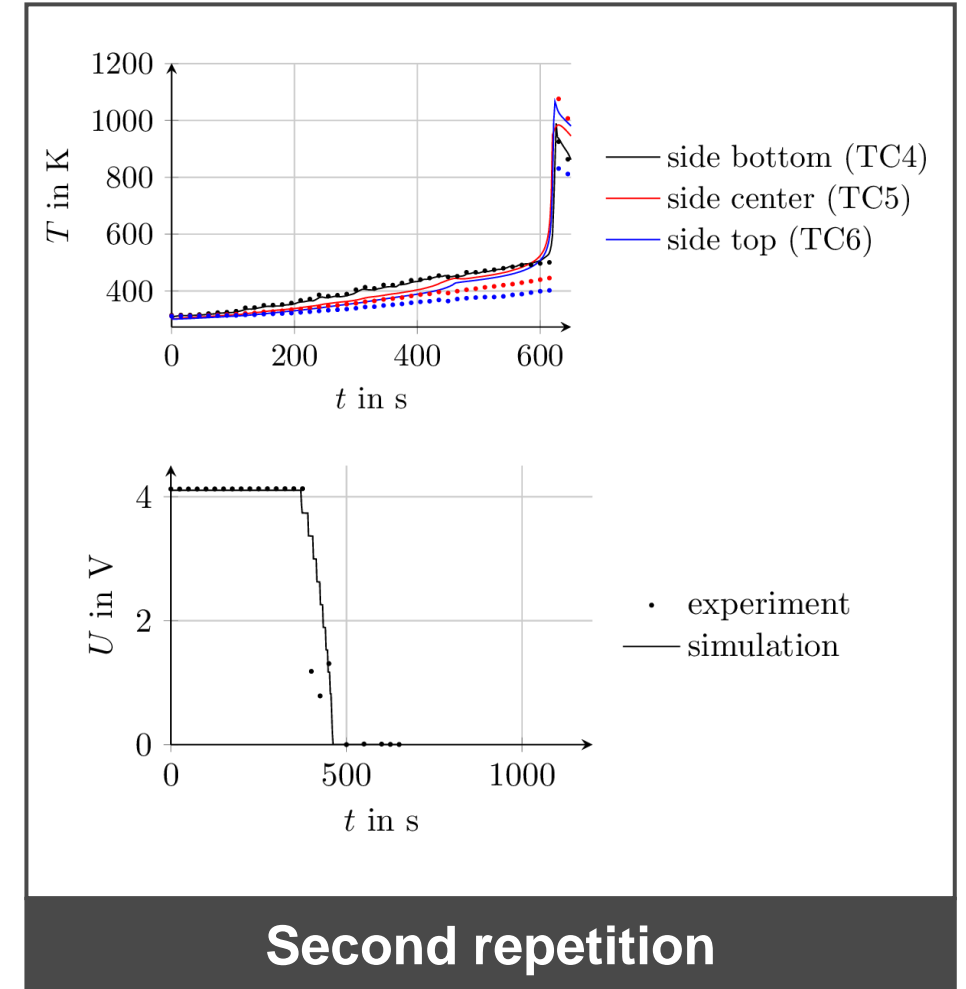
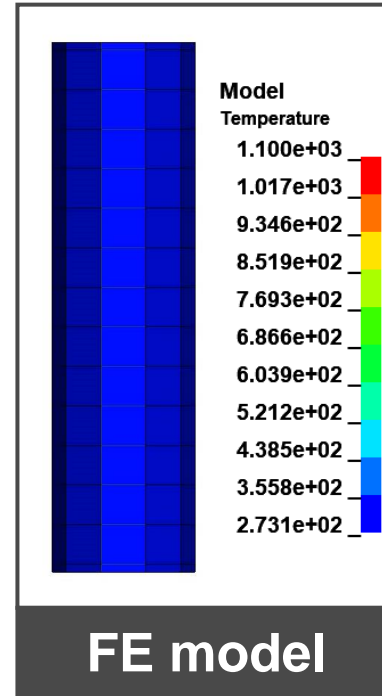
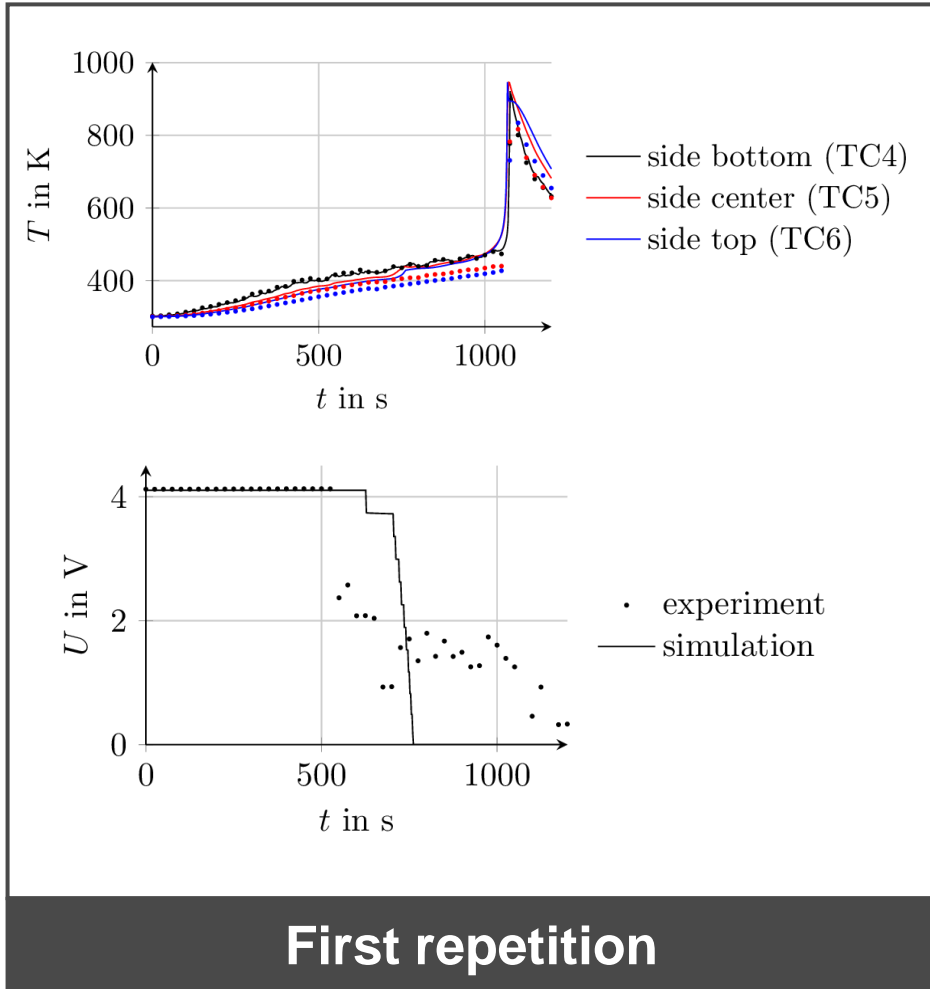

Application of a single cell model within the simulation of multi-cell mockups

Mockup with equal distances

Experimental investigation

- Thermal runaway of the center cell induced by heating with a heating wire
- Temperature and voltage measurement at each cell
- Video recording with high-speed camera

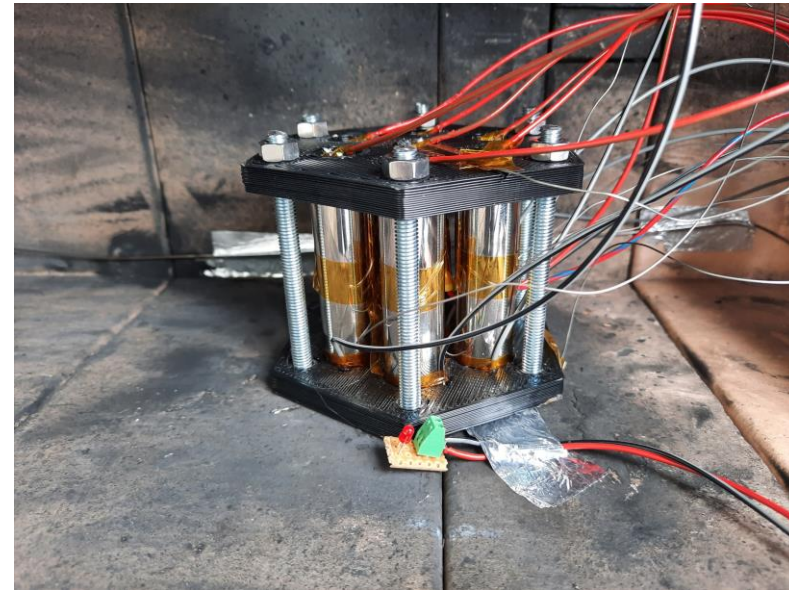
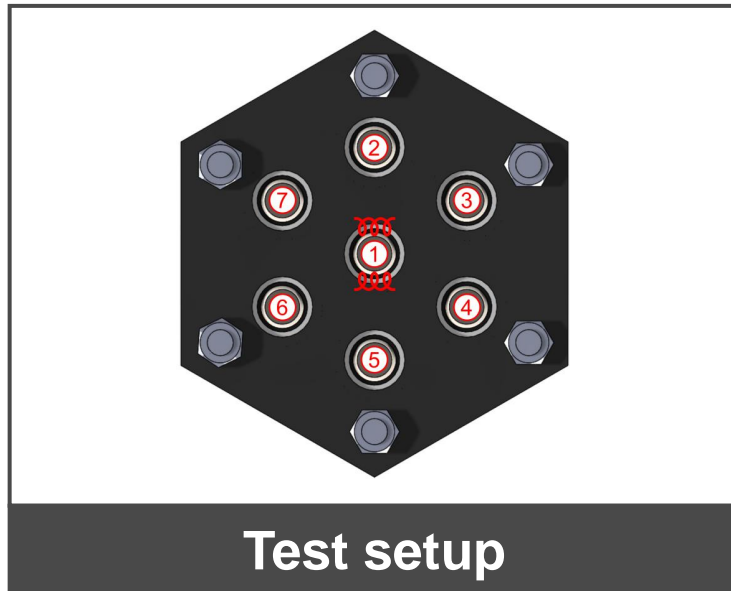

Mockup with equal distances

Experimental investigation

Mock-up with seven 18650 battery cells
equal distances

Mockup with equal distances

Experimental investigation – behavior of all cells

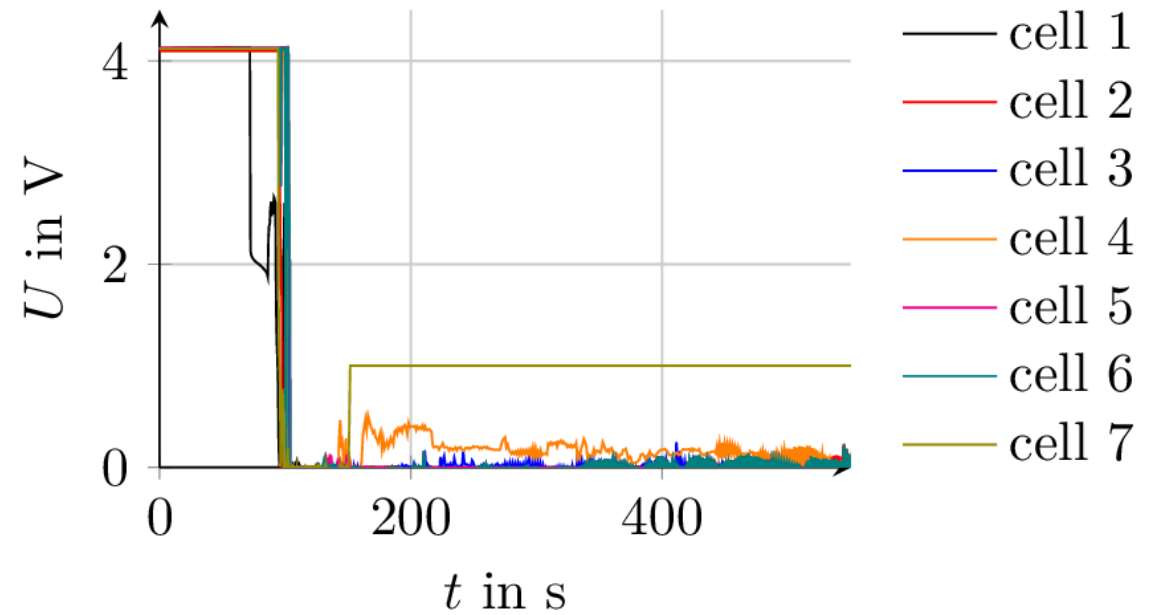
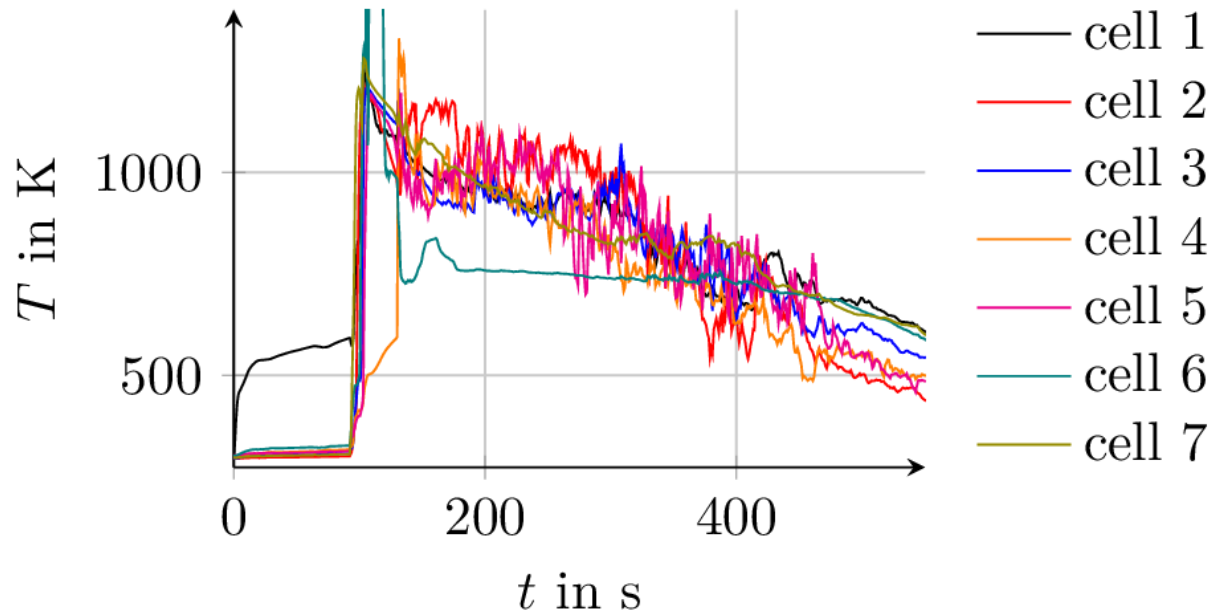
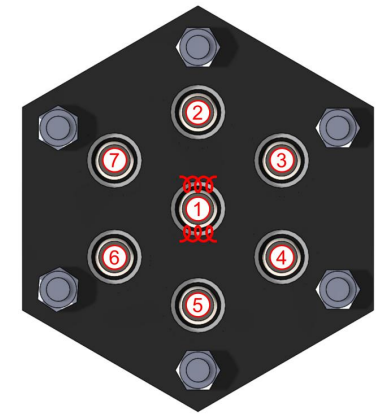

*Thermocouple at cell 6 was broken within the test

Mockup with equal distances

Experimental investigation – behavior of all cells

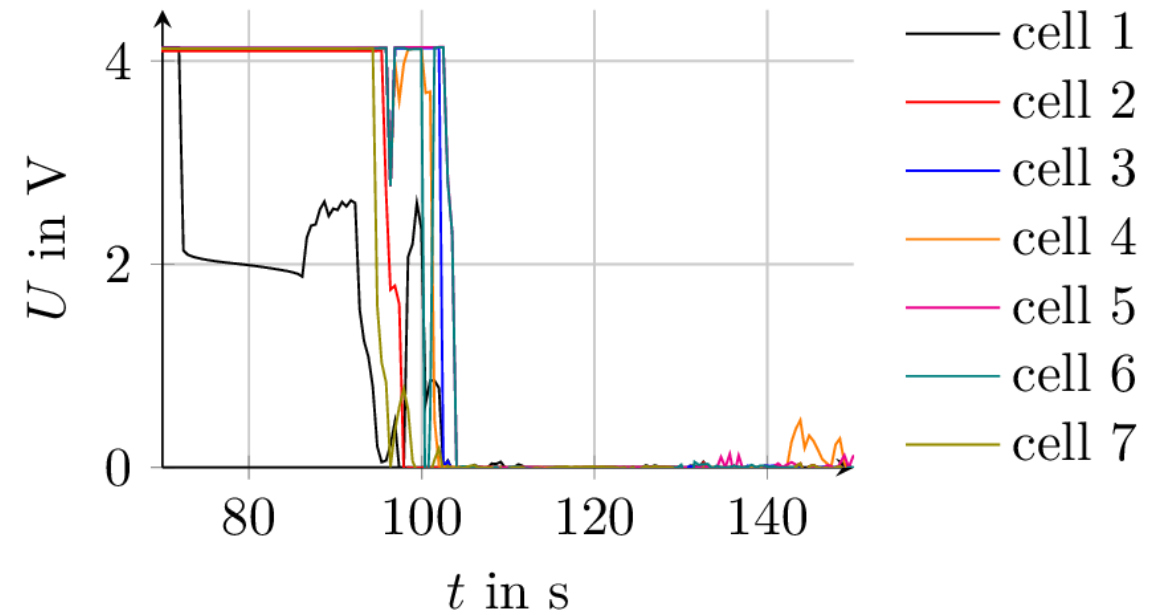
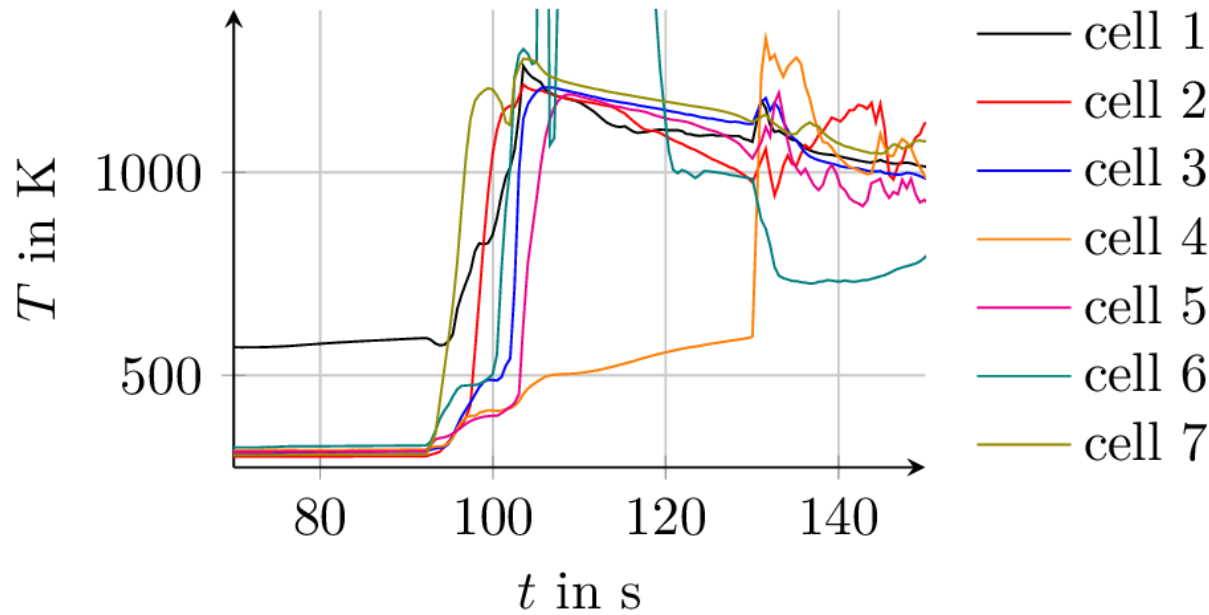
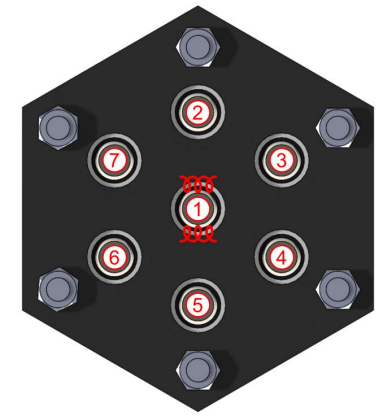

*Thermocouple at cell 6 was broken within the test

Mockup with equal distances

Experimental investigation – behavior of cell 1 and 2

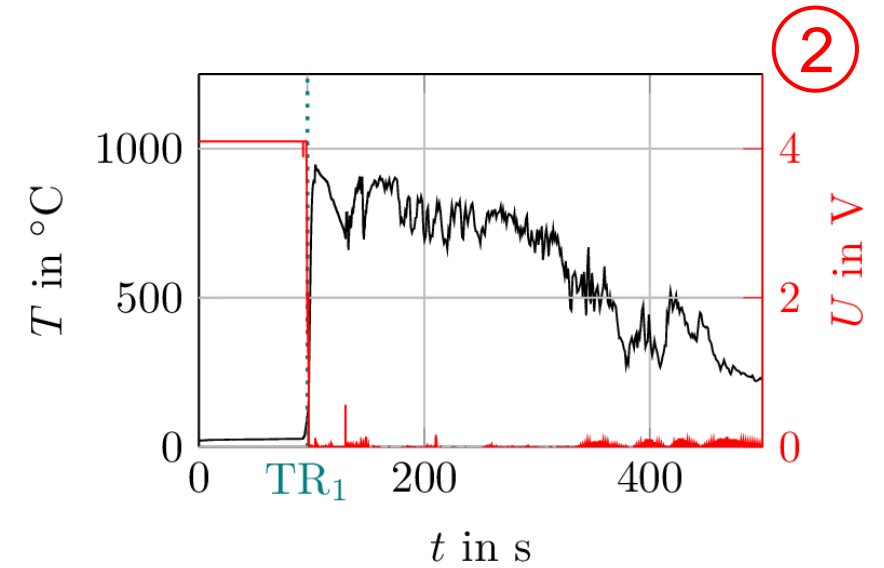
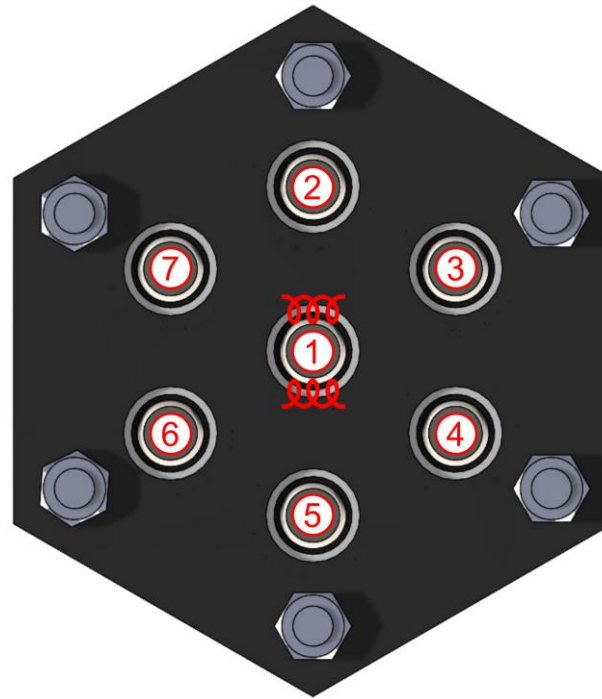
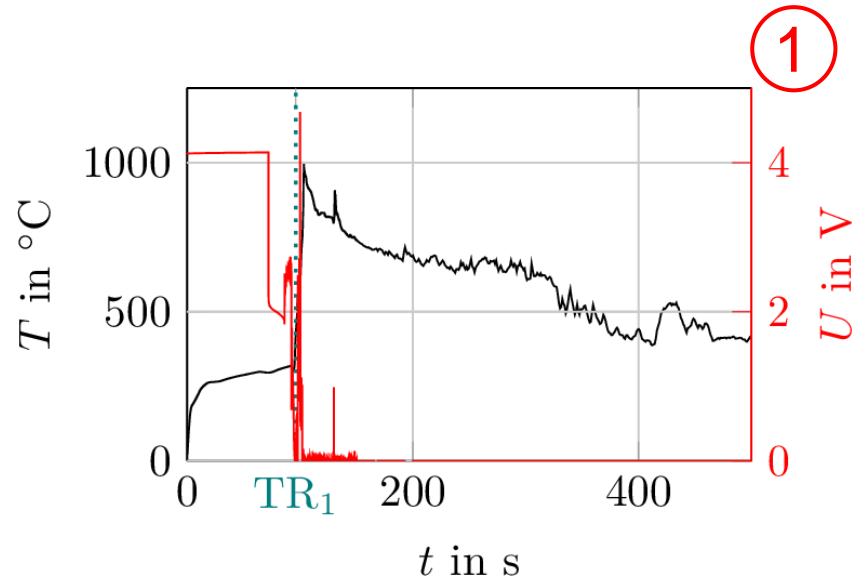

Mockup with equal distances

Simulation results

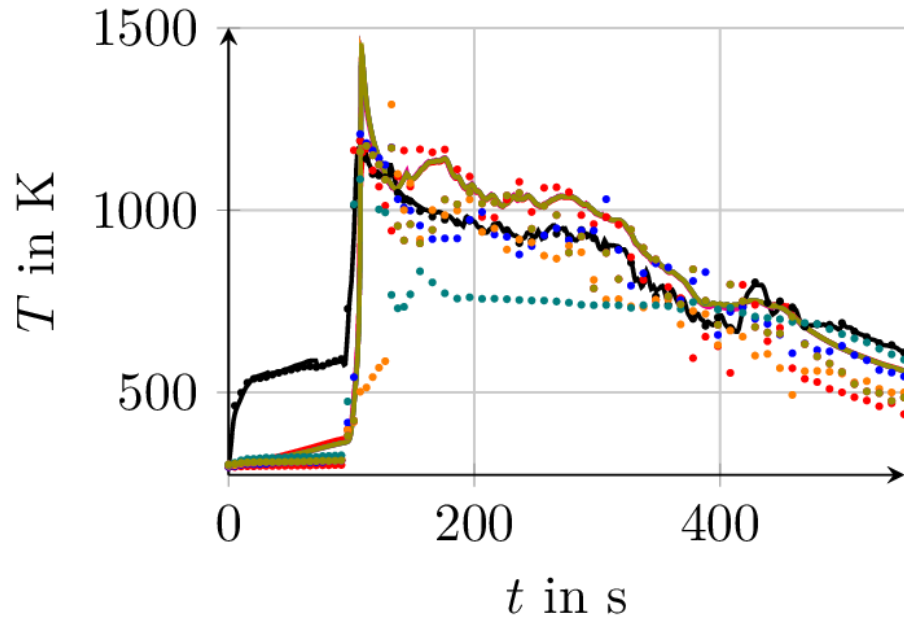
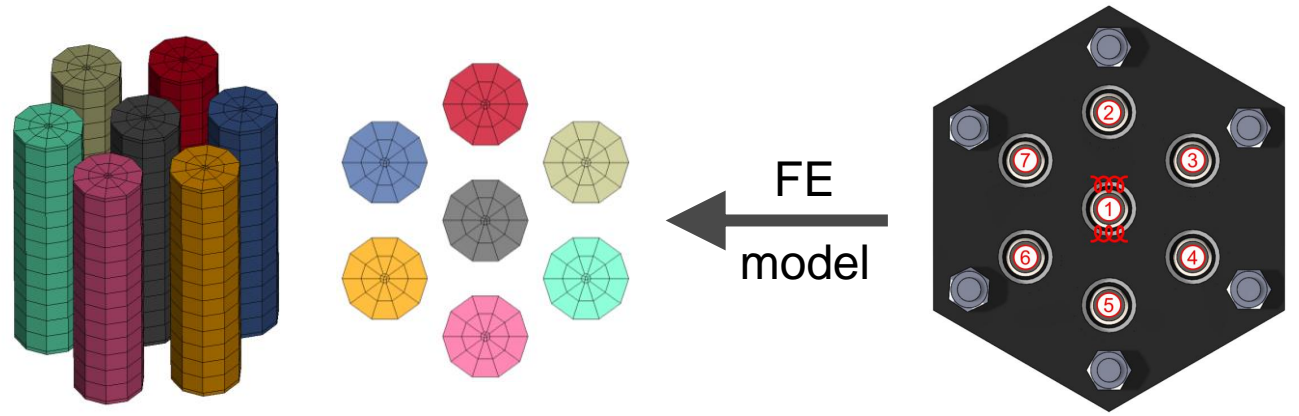

- cell 1
- cell 2
- cell 3
- cell 4
- cell 5
- cell 6
- cell 7

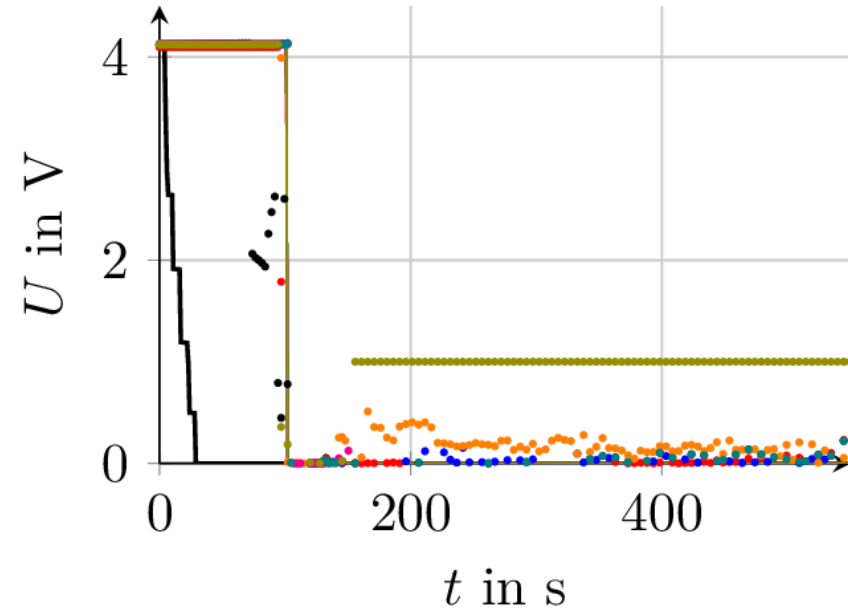

- cell 1
- cell 2
- cell 3
- cell 4
- cell 5
- cell 6
- cell 7

• experiment — simulation

Mockup with different distances

Experimental investigation

- Thermal runaway of the center cell induced by heating with a heating wire
- Temperature and voltage measurement at each cell
- Video recording with high-speed camera

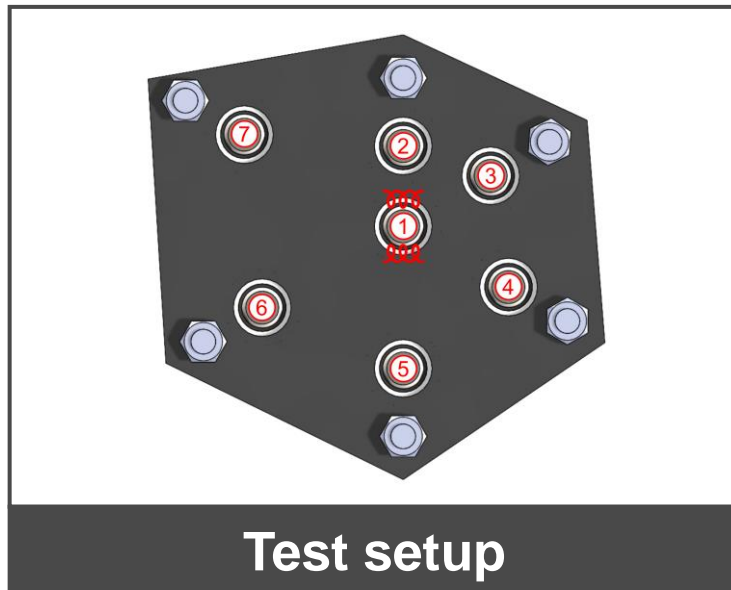

Mockup with different distances

Experimental investigation

Mock-up with seven 18650 battery cells
different distances

Mockup with different distances

Experimental investigation – behavior of all cells

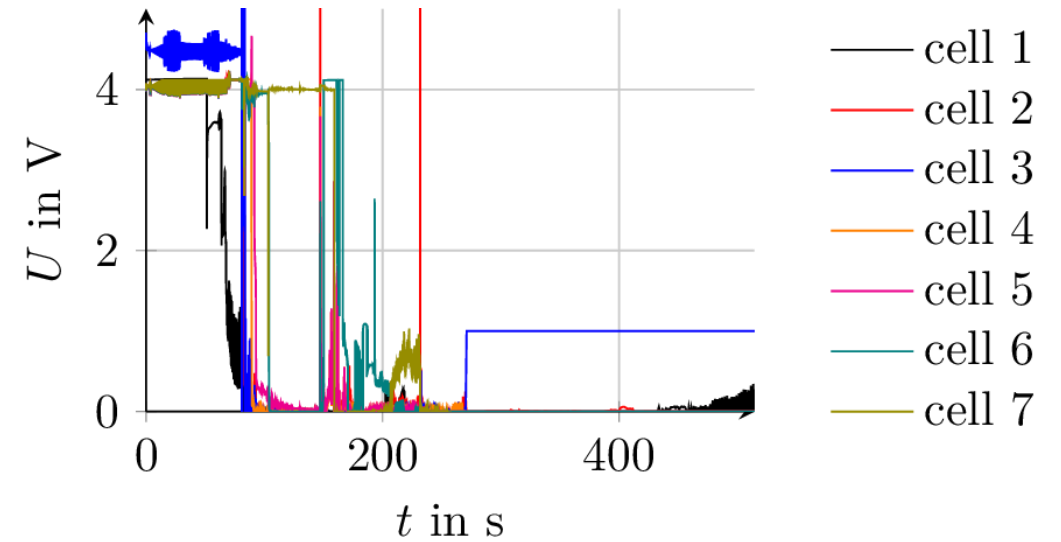
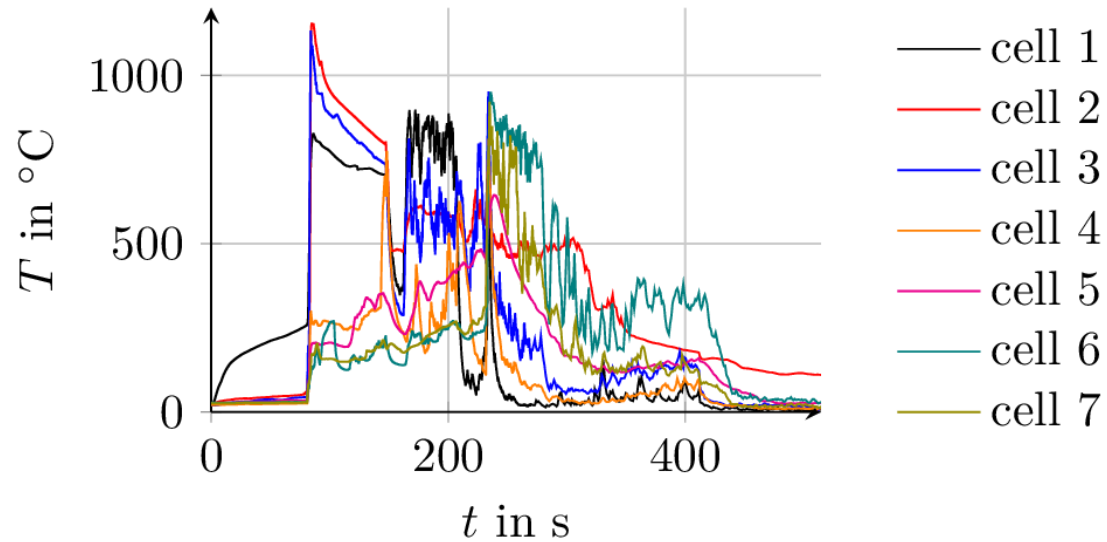
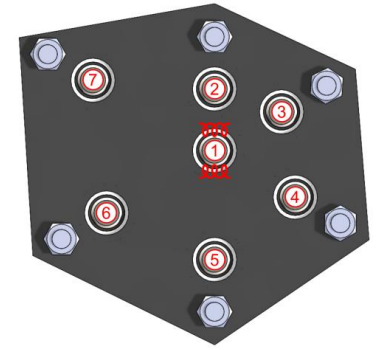

Mockup with different distances

Experimental investigation – behavior of all cells

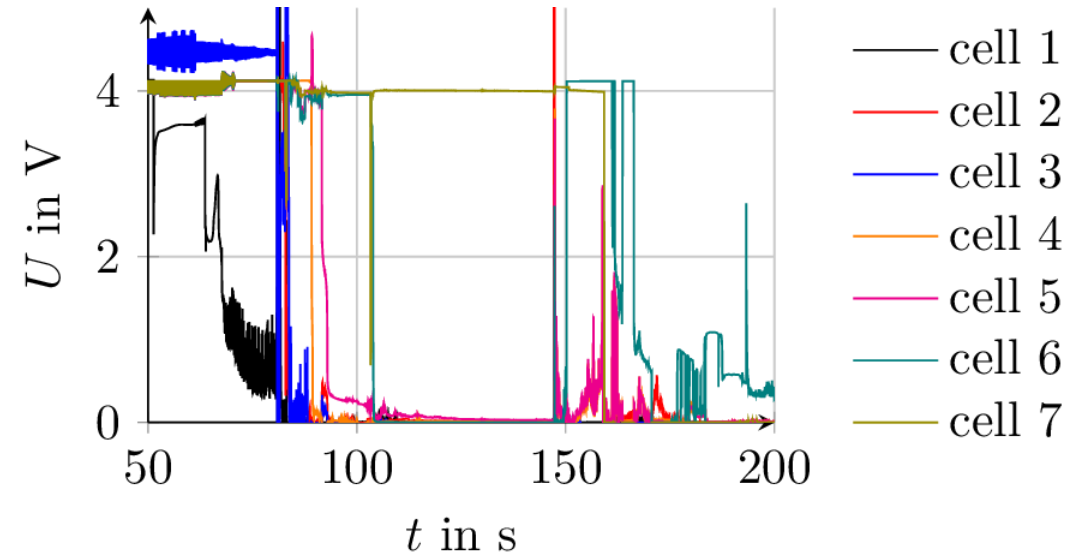
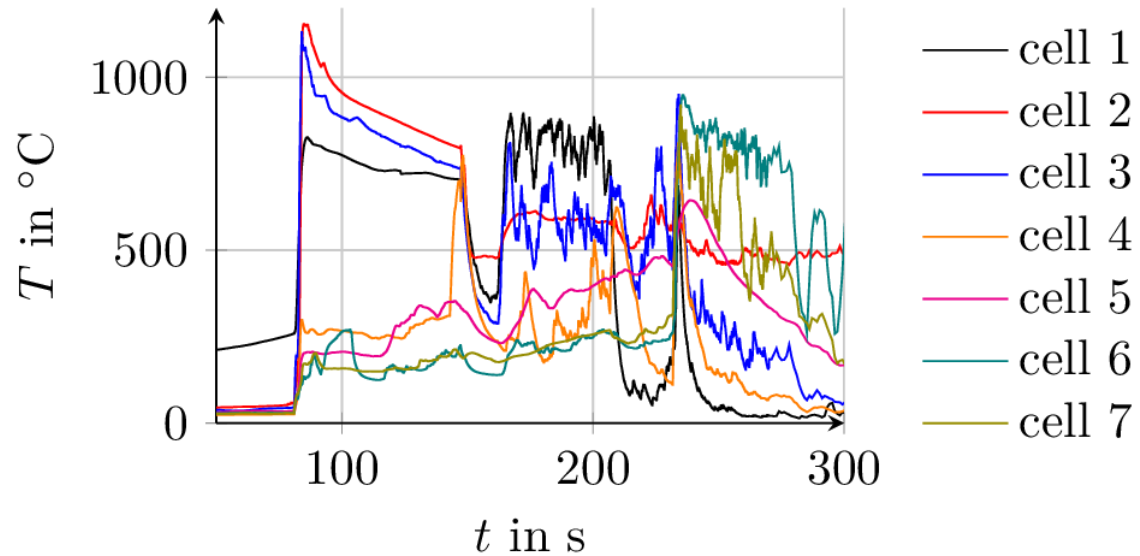
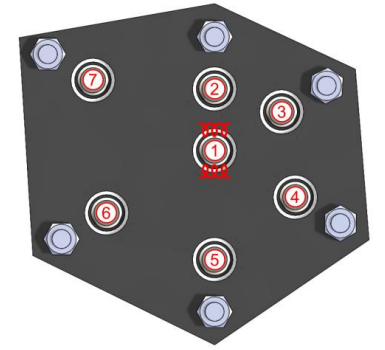

Mockup with different distances

Simulation results

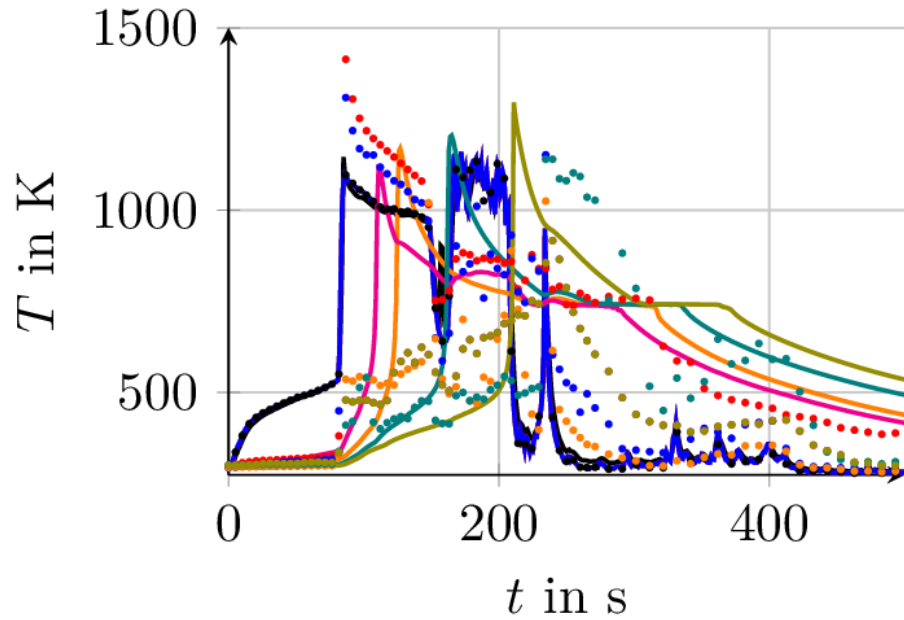
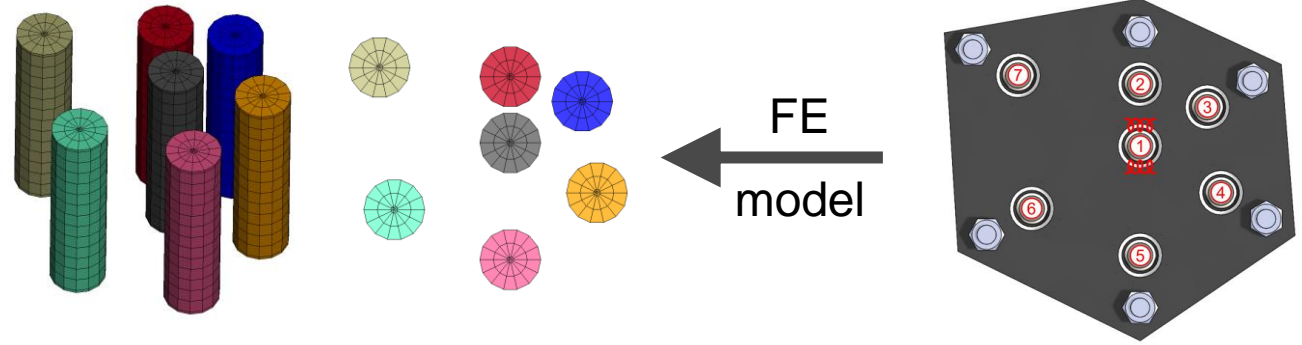

- cell 1
- cell 2
- cell 3
- cell 4
- cell 5
- cell 6
- cell 7

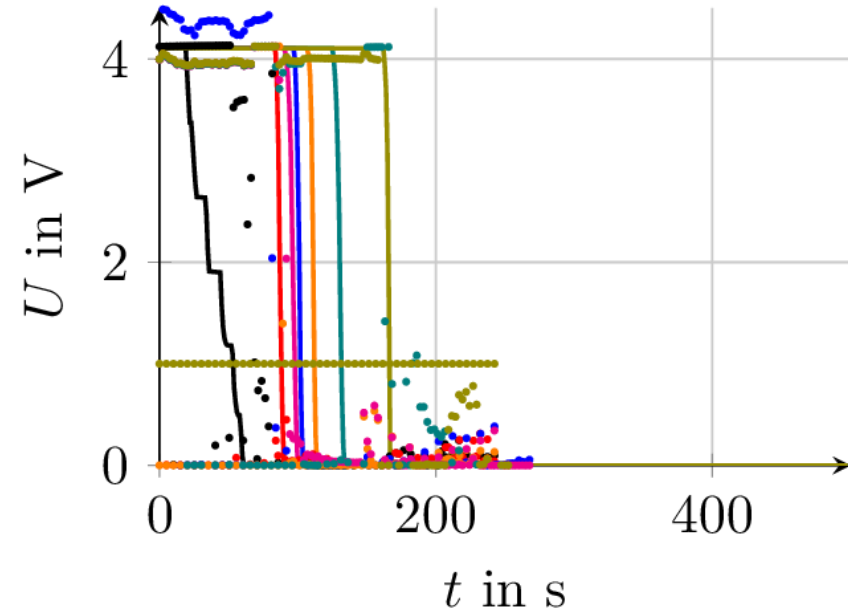

- cell 1
- cell 2
- cell 3
- cell 4
- cell 5
- cell 6
- cell 7

• experiment — simulation

Conclusion and outlook

Conclusion

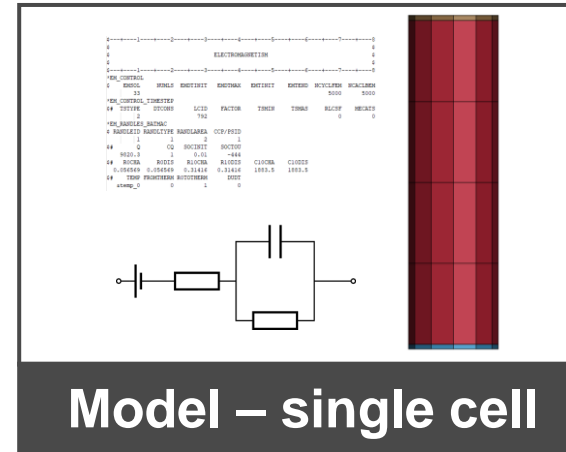
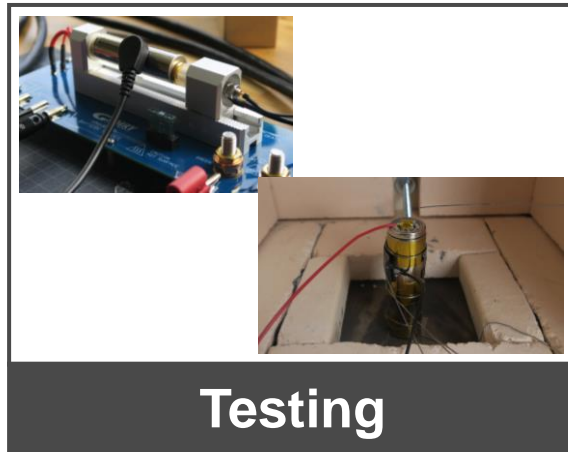

Outlook

- Development of test setups for further characterizations of battery cells especially within the thermal runaway
- Automatic identification of the parameters required for the resulting FE model
- Optimization of battery packs addressing the thermal propagation behavior

Conclusion

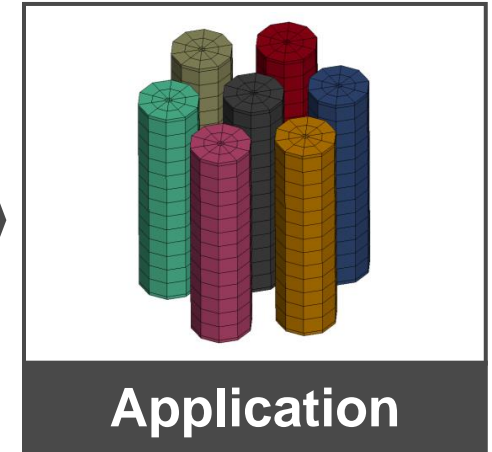
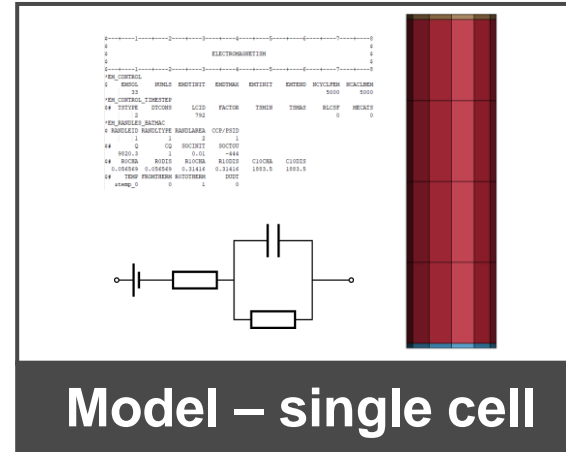
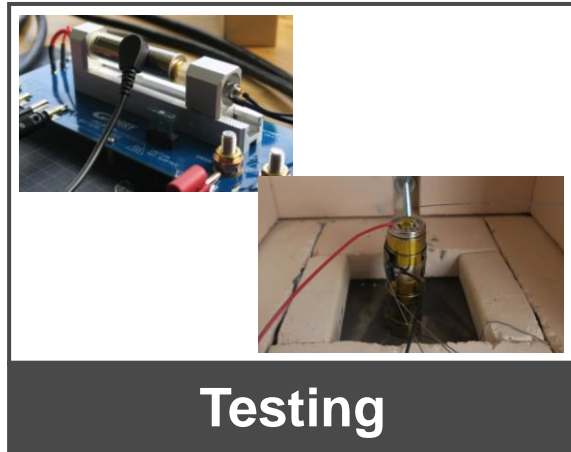

Outlook

- Development of test setups for further characterizations of battery cells especially within the thermal runaway
- Automatic identification of the parameters required for the resulting FE model
- Optimization of battery packs addressing the thermal propagation behavior

Improve your developments with our expertise in testing and simulation!



Martin Schwab

martin.schwab@4a.at

