

IMPETUS[®] - new efficient dynamic tensile test

S. Riemelmoser, Ch. Schober, M. Rollant - 4a engineering GmbH
Technology Day, 03.03.2020



Outline

- IMPETUS® - dynamic tensile test setup
- Measurement technique
- Testing procedure
- Live test
- Test results

IMPETUS® - main characteristics



- Desktop testing device
 - ready to use
- Instrumented high speed testing
 - measured \rightarrow force / displacement
- Impact speed 0.5 – 4.5 m/s
- Maximal energy up to 50 J
- High speed camera
 - sync. recording

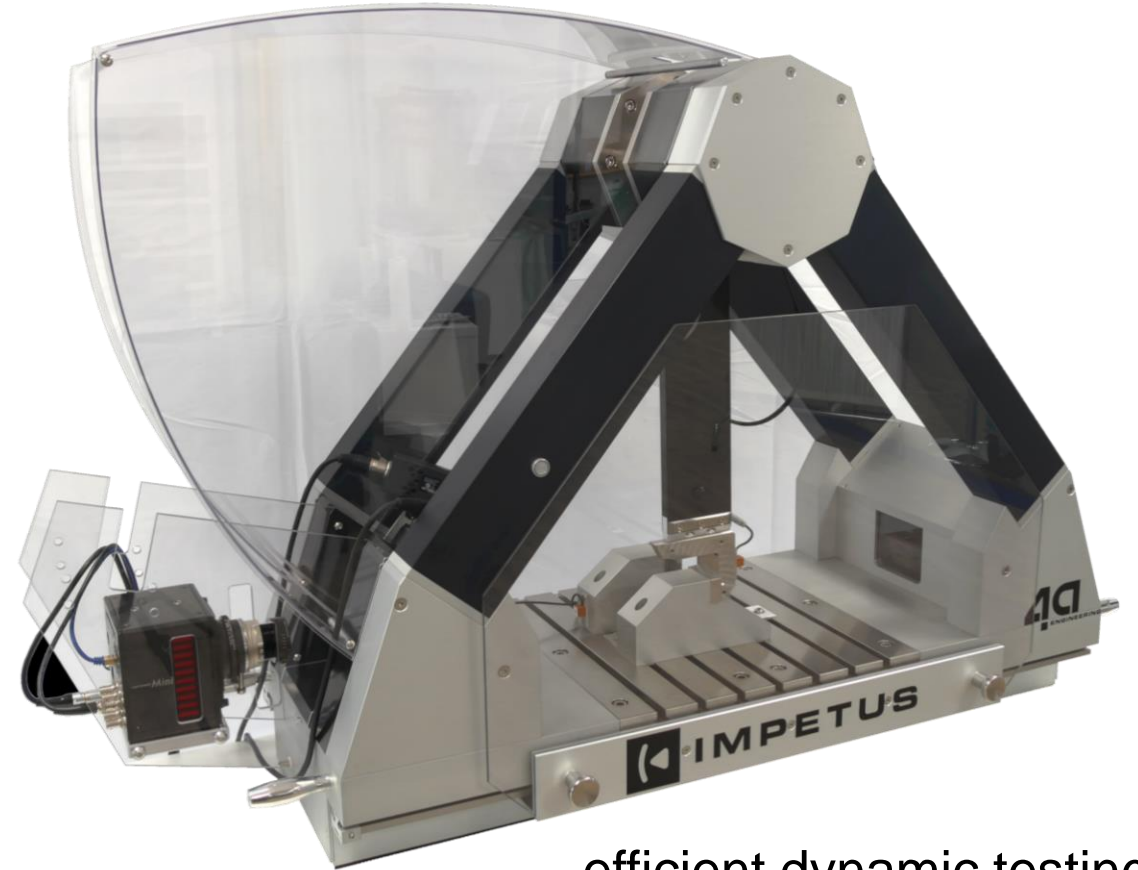

efficient dynamic testing
plastics and composites

IMPETUS® - universal testing machine



3 POINT BENDING

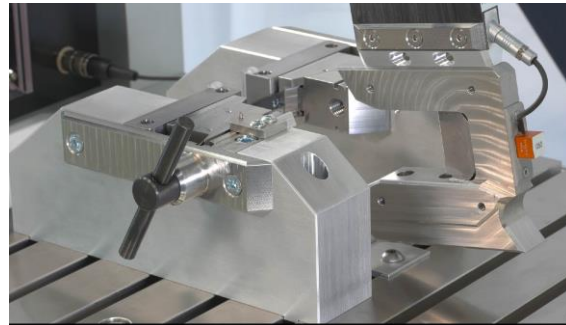

TENSION BENDING

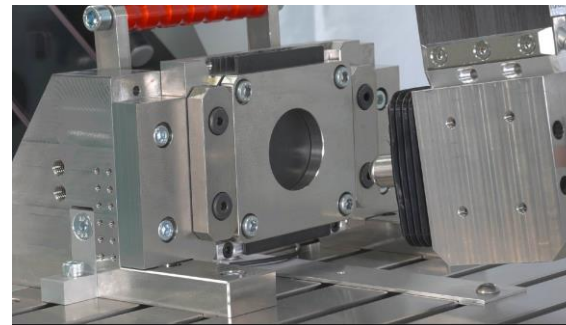

PUNCTURE TEST



TENSION TEST

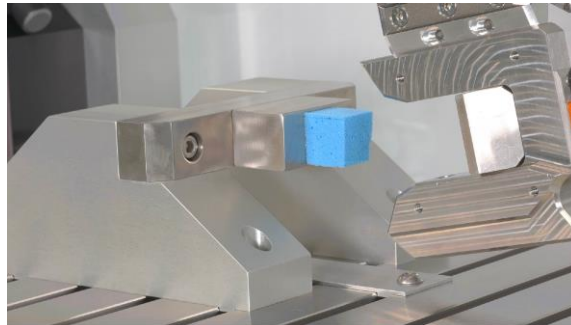

COMPRESSION TEST

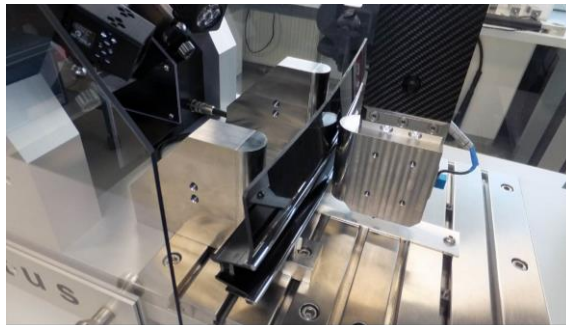

COMPONENT TEST



SAMPLE MAGAZIN

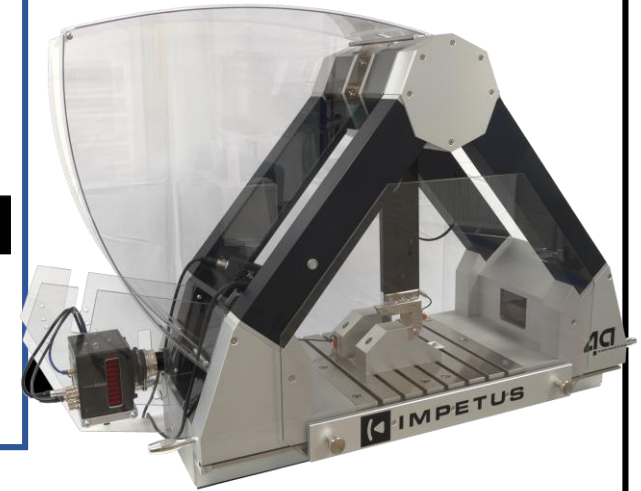

BASIC

STANDARD

PROFESSIONAL

IMPETUS® - dynamic tensile test

- Hardware consists of 3 main parts
 - counter bearing system
 - sample clamping
 - pendulum impactor head
→ Ease of use operation!

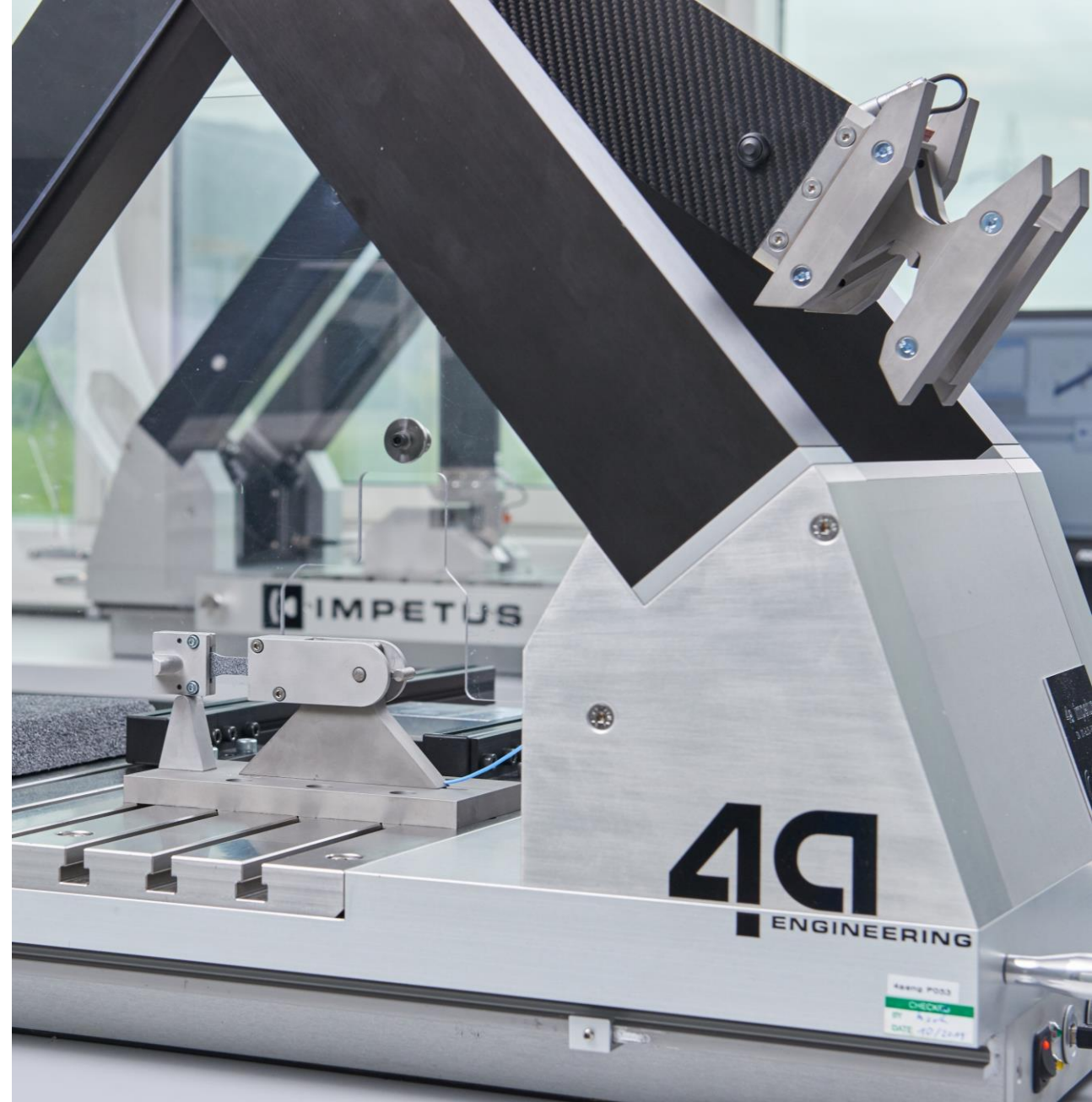
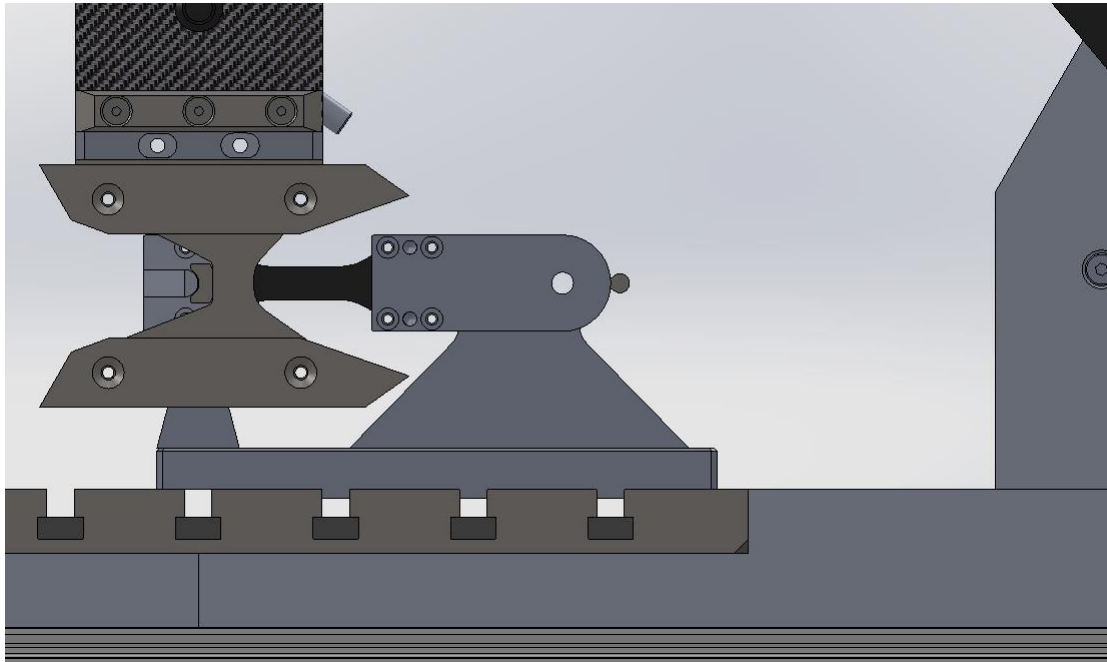

Measurement technique

What we basically measure during the test?

- Time [ms]
 - time-synchronous data is essential
- Force [N]
 - piezo load cell 20 kN
- Stroke [mm]
 - incremental angle sensor
 - **digital image correlation (DIC)** → **Now it's getting complex, isn't it?**

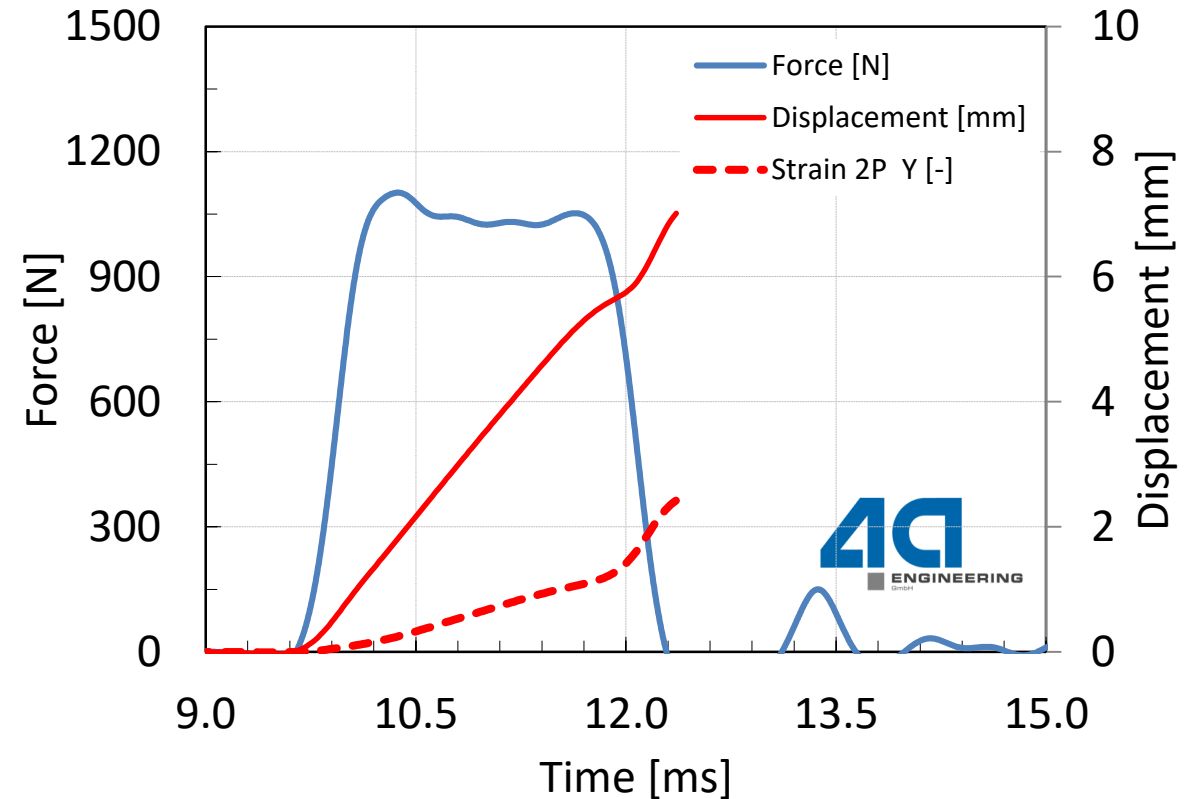

Measurement technique with DIC

Now it's getting complex, isn't it?

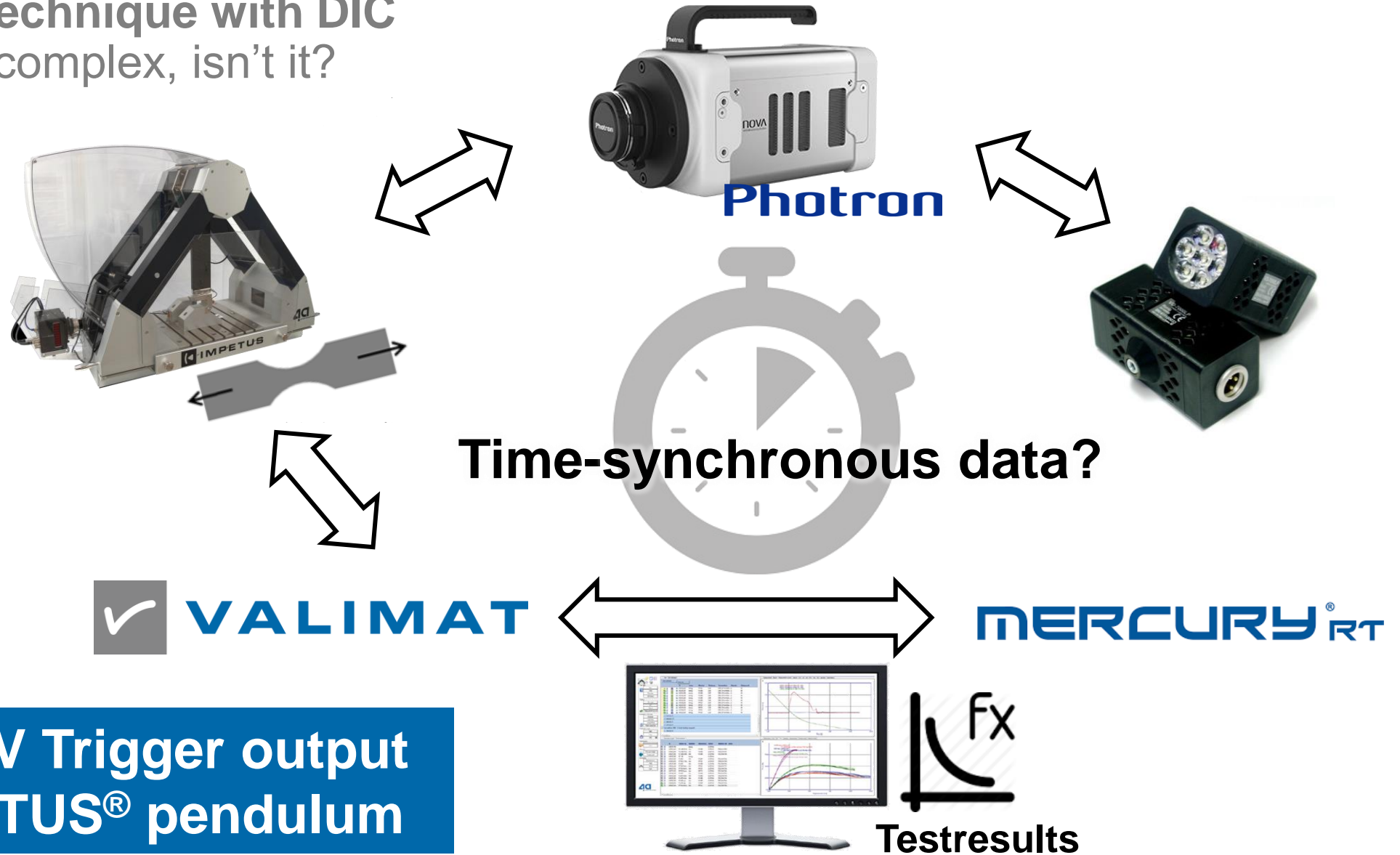

**Integrated 5V Trigger output
at the IMPETUS[®] pendulum**

Measurement technique with DIC

Now it's getting complex, isn't it?

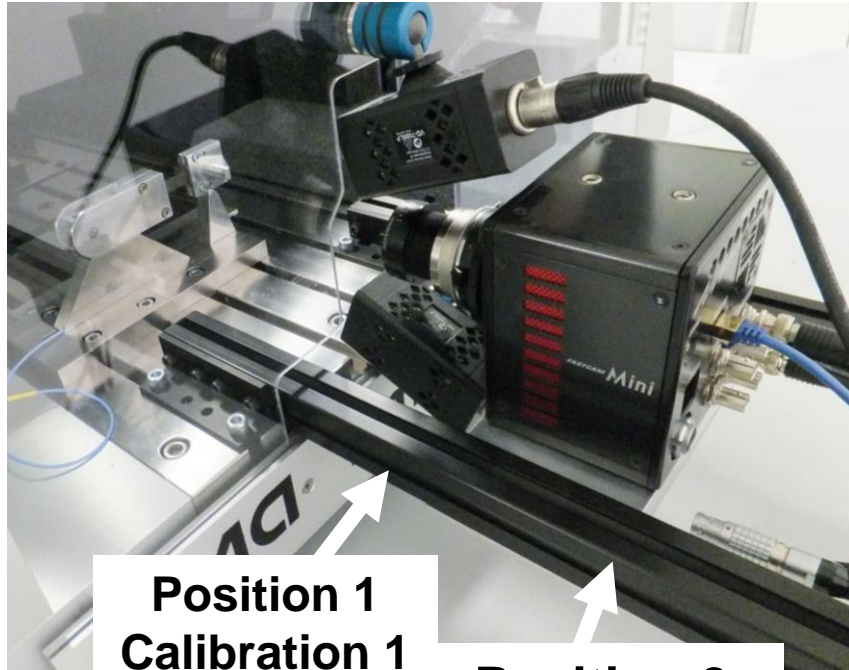

Position 1
Calibration 1

Position 2
Calibration 2

**Predefined camera positions
attached to the pendulum**

Calibrated DIC recording?

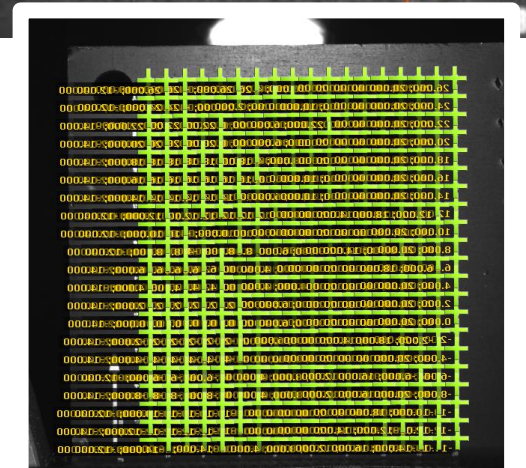
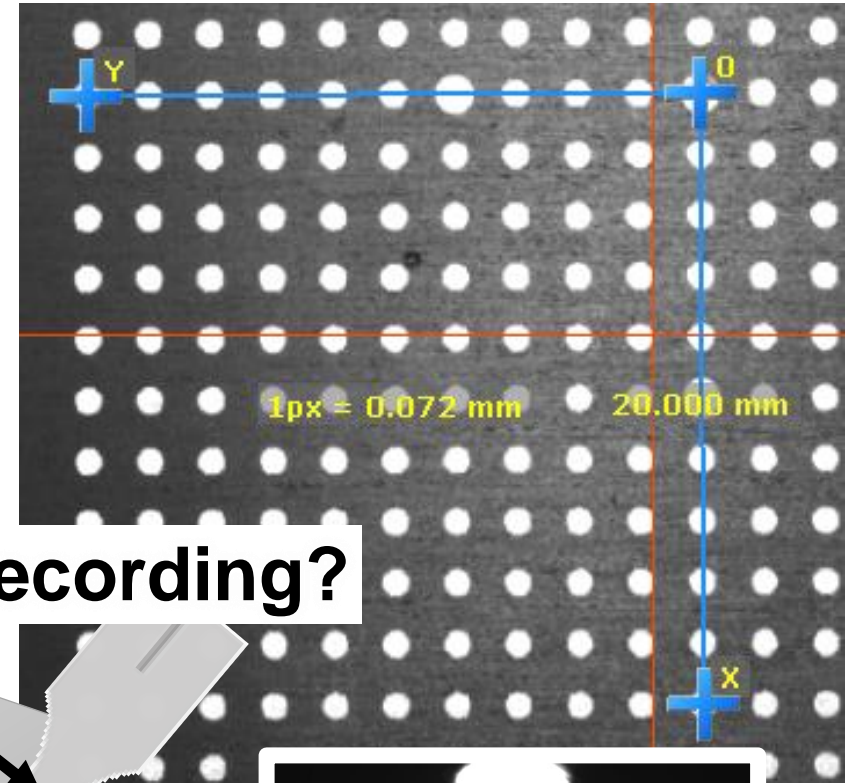

Measurement technique with DIC

Now it's getting complex, isn't it?

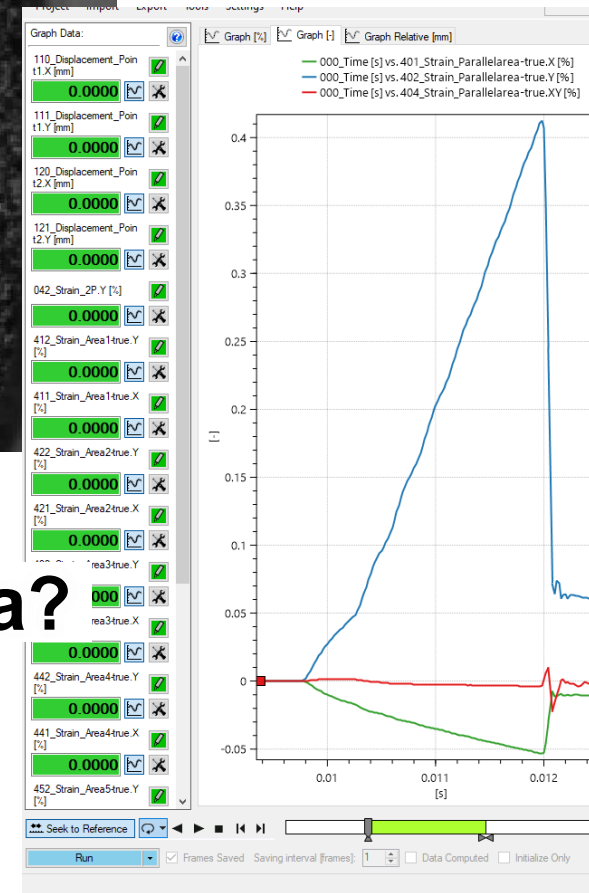
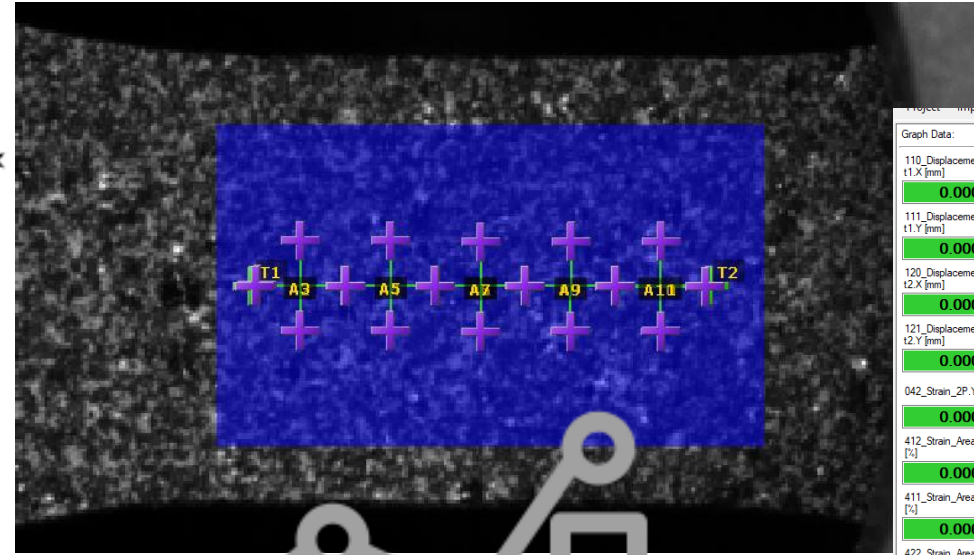
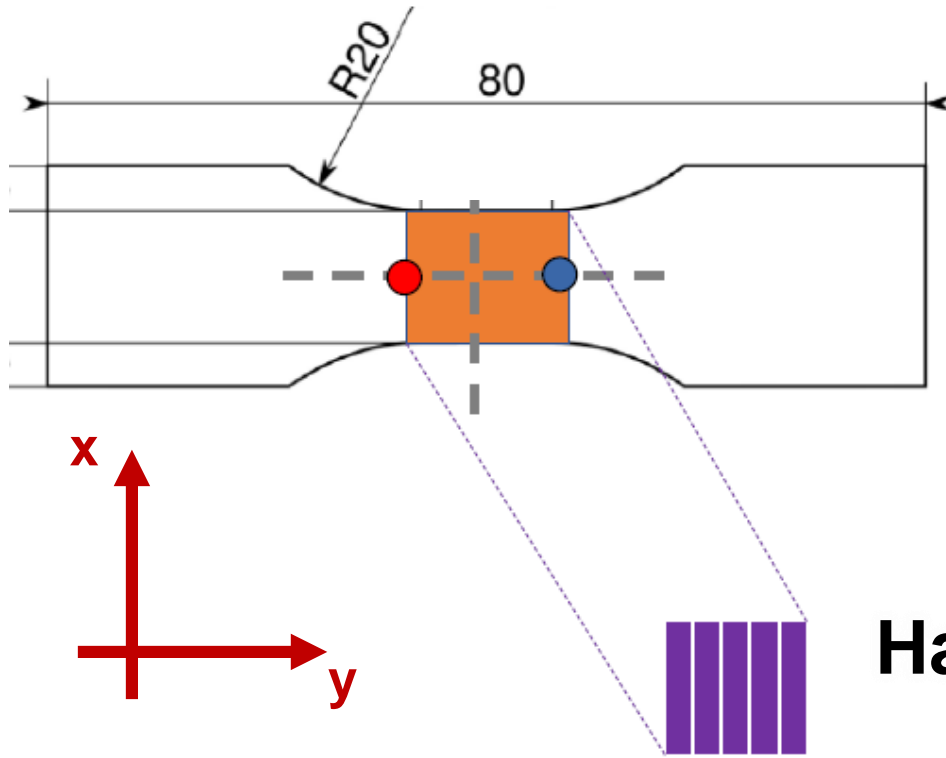

Handling the recorded data?

DIC "standard" nomenclature for optical measurement data

Measurement technique with DIC

It's not complicated!



Integrated 5V Trigger output
at the IMPETUS[®] pendulum

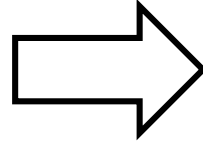

Time-synchronous data!

Predefined camera positions
attached to the pendulum

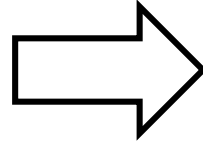

Calibrated DIC recording!

DIC "standard" nomenclature
for optical measurement data

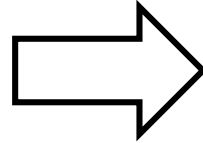

Easy data handling!

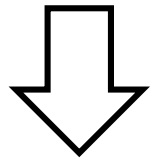

Efficient dynamic testing!

Testing procedure

- Sample preparation with the speckle pattern
- Attaching the jig to the specimen
- Put the prepared sample at the counter bearing
- Perform the dynamic tensile test



Have to be done manually

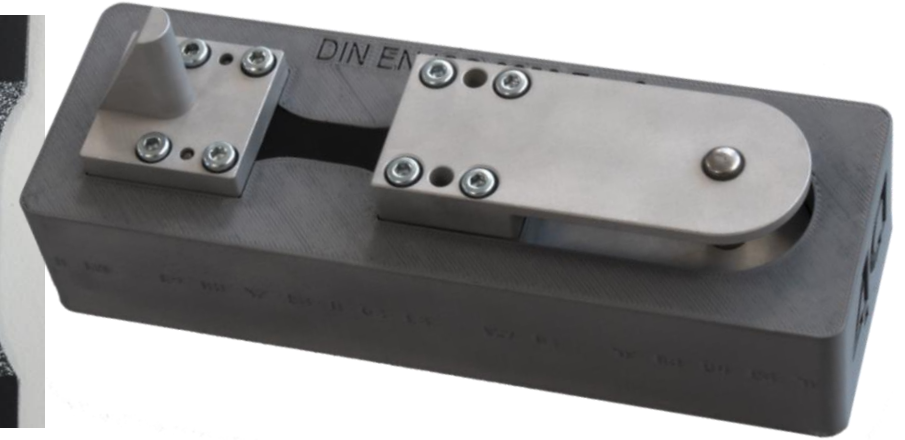

Is executed automatically

- Activate the bright lights
- Start the recording of the high-speed camera
- Immediately evaluate the DIC images
- Finally store the recorded data in the VALIMAT database

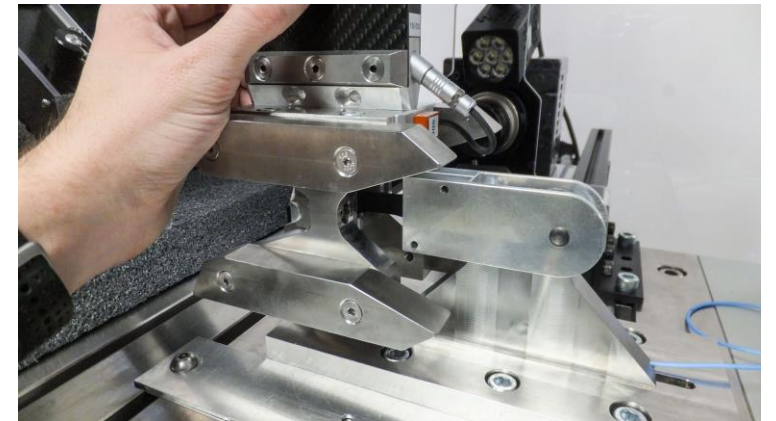

Live test procedure



Dynamic tensile test - unreinforced plastic comparison 4a IMPETUS / external ZWICK

External ZWICK
4a IMPETUS

Typ A, 3m/s

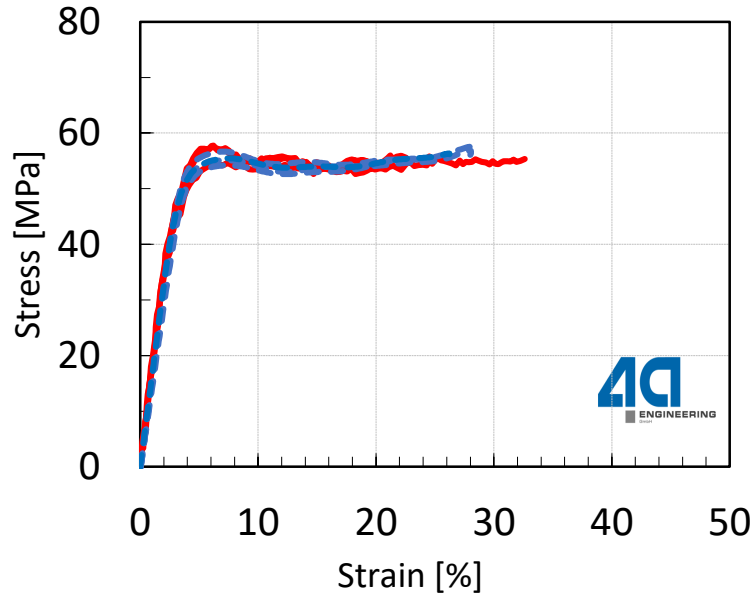

Typ B, 3m/s

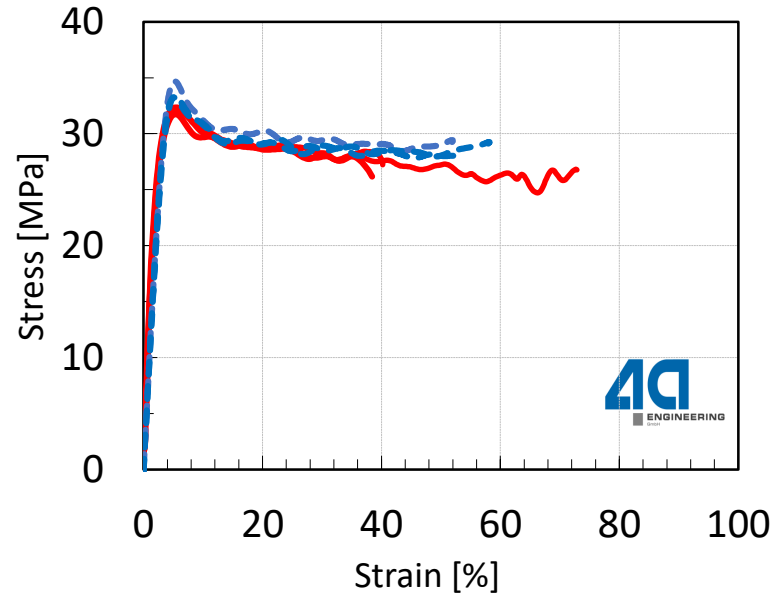

Typ C, 3m/s

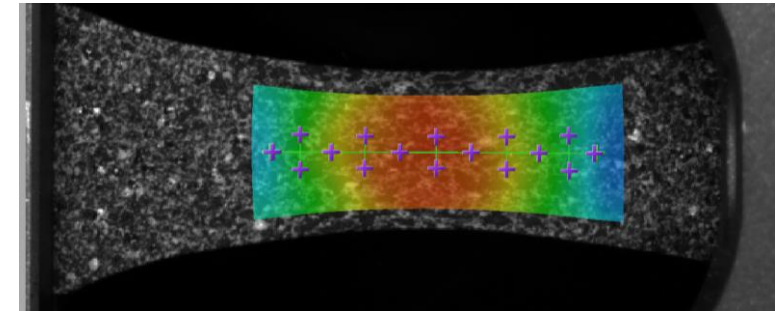
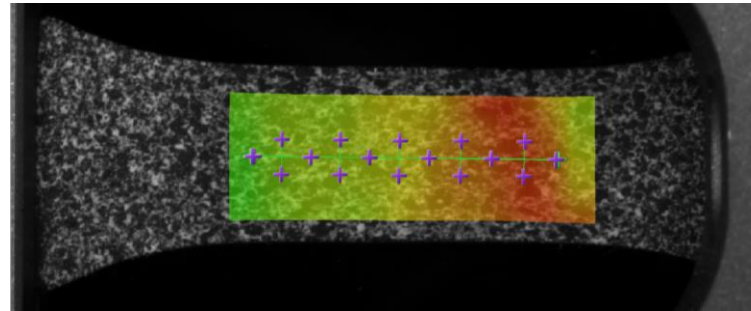
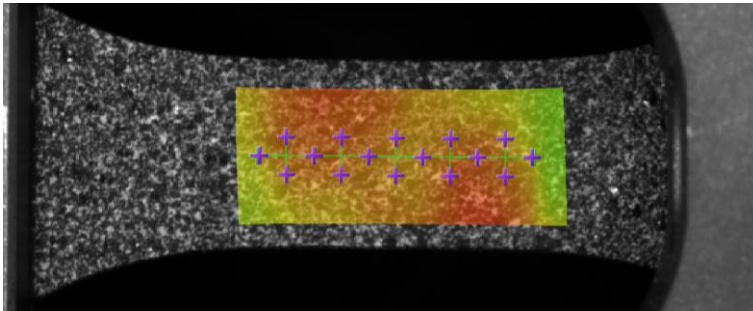
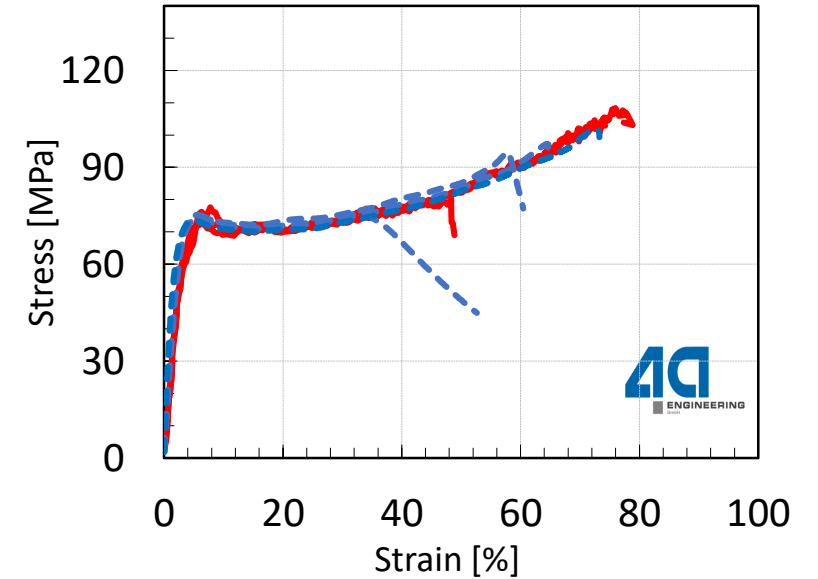

Dynamic tensile test – reinforced plastic PPLGF30 comparison 4a / external

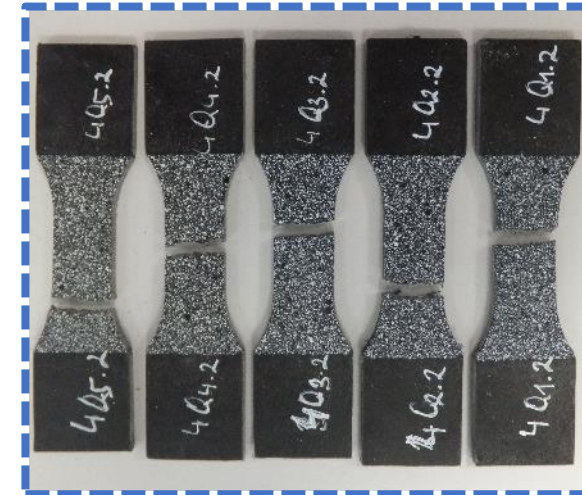
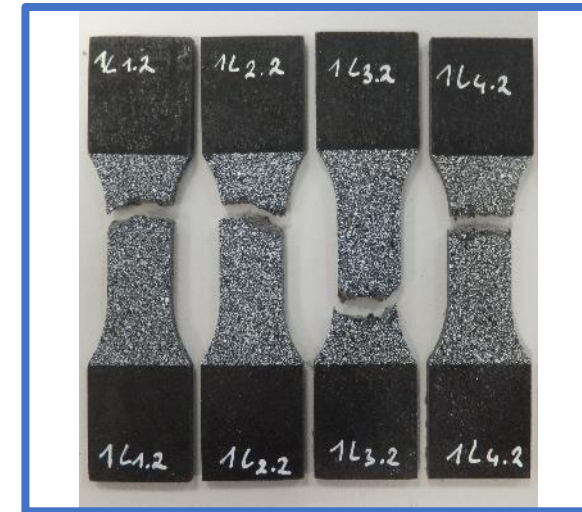
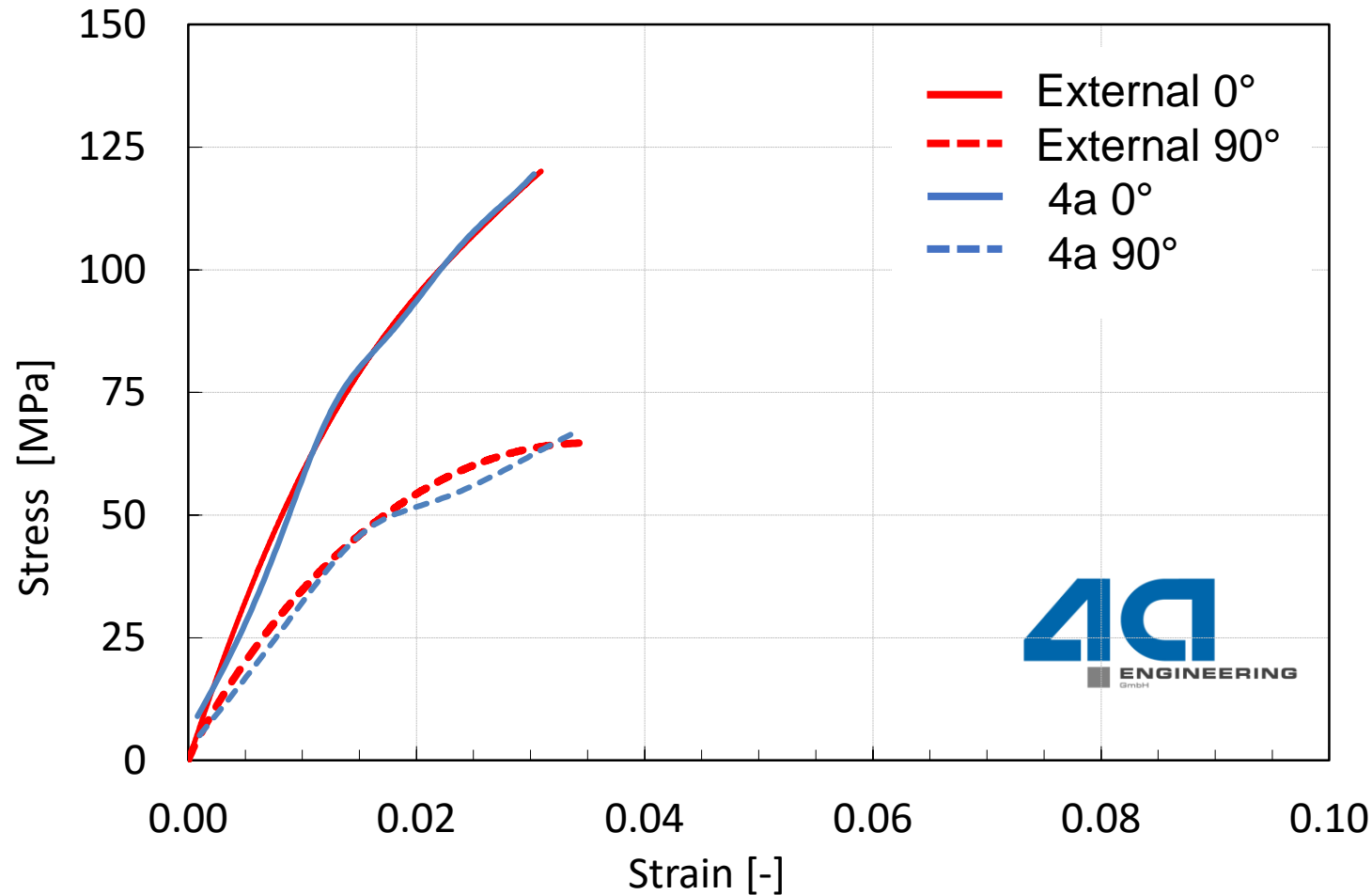

With the kind support by  **Celanese**



Summary and outlook

- Automatic test evaluation without manual intervention in between
 - Efficient dynamic testing!
- AiF project new upcoming standard
 - ISO 8256 Typ3
 - new 4a injection mould

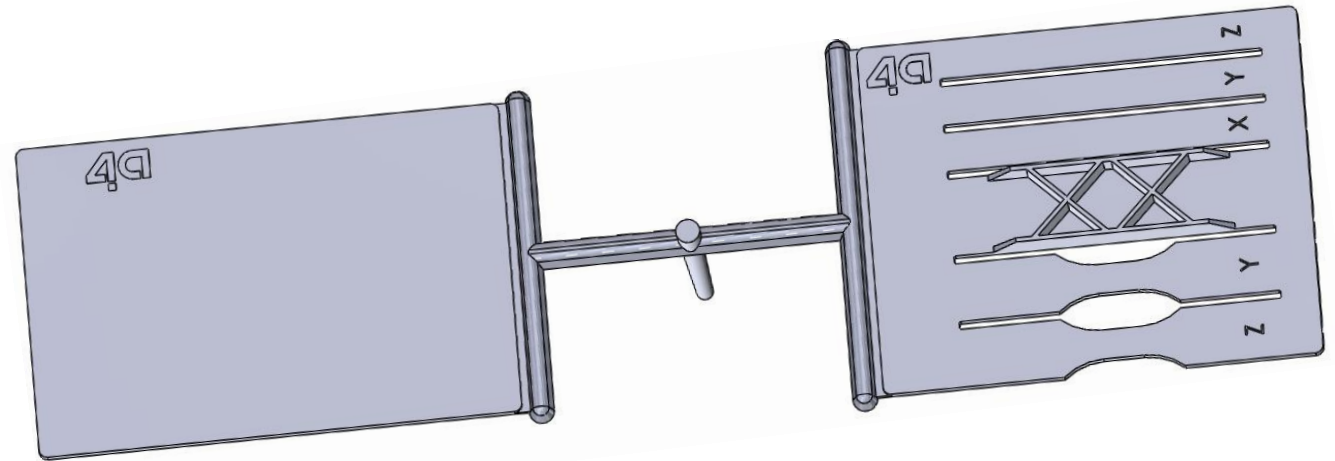
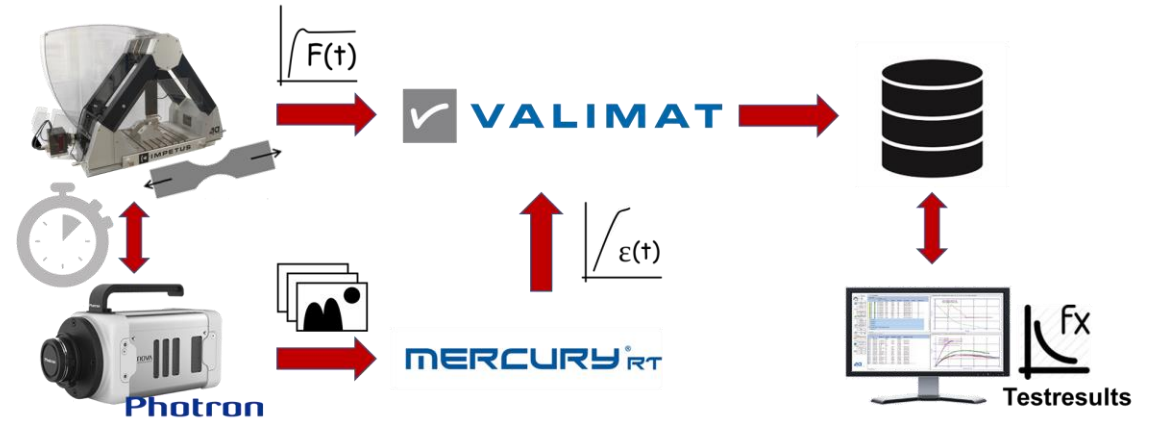

Thank you for your attention

S. Riemelmoser - 4a engineering GmbH
Technology Day, 03.03.2020

